

# *Remote Control Panel*

---

## **Operating Instructions**

Before operating the unit, please read this manual thoroughly and retain it for future reference.

## **RCP-TX7**

**For the customers in the USA**

This equipment has been tested and found to comply with the limits for a Class A digital device, pursuant to Part 15 of the FCC Rules. These limits are designed to provide reasonable protection against harmful interference when the equipment is operated in a commercial environment. This equipment generates, uses, and can radiate radio frequency energy and, if not installed and used in accordance with the instruction manual, may cause harmful interference to radio communications. Operation of this equipment in a residential area is likely to cause harmful interference in which case the user will be required to correct the interference at his own expense.

You are cautioned that any changes or modifications not expressly approved in this manual could void your authority to operate this equipment.

This device requires shielded interface cables to comply with FCC emission limits.

# Table of Contents

<b>Overview .....</b>	<b>4</b>
<b>Location and Function of Parts .....</b>	<b>5</b>
Operation Panel and Connector .....	5
<b>1</b> Main Operation Section .....	5
<b>2</b> Menu Operation/Setting Display Section .....	7
<b>3</b> Paint section and CALL button .....	8
<b>Menu Operations .....</b>	<b>12</b>
Displaying menus .....	12
Basic Menu Operations .....	14
Menu Contents .....	15
<b>File Operations .....</b>	<b>21</b>
Operating Scene Files .....	23
Operating Setup Files (for DXC-D30/D30P Only) .....	24
<b>Skin Detail Correction/Skin Matrix Adjustment (for DXC-D30/D30P Only) .....</b>	<b>25</b>
<b>Multi-Camera Control .....</b>	<b>26</b>
Operating Multiple Cameras from One RCP Unit — Command Link .....	26
Adjusting the Iris and Master Black of Multiple Cameras at One Time .....	27
Data Transfer Among Multiple Cameras .....	27
<b>Specifications .....</b>	<b>28</b>

# Overview

The RCP-TX7 Remote Control Panel enables remote operation of the DXC-D30/D30P or DXC-637 series Color Video Camera.

This unit's features are described below.

---

## Connectable to camera control unit or camera head

When a CCU (CCU-TX7/TX7P Camera Control Unit) has been connected to a CA (CA-TX7/TX7P Camera Adaptor) that is docked with a camera head, this unit can be connected to the CCU to enable remote operation of the camera via the CCU.

When the DXC-D30/D30P is docked with a CA-537/537P Camera Adaptor or VCR, this unit can be connected to the DXC-D30/D30P to enable direct operation of the camera.

---

## Full control of shooting operations

Besides controlling camera adjustments and settings, this unit can control tripod operations (pan and tilt) and lens settings (focus and zoom).

---

## Confirmation of camera conditions and operation status

This unit's LCD panel indicates camera conditions such as the optical filter position, value, and lens extender setting. The results of the camera's self-diagnosis tests are also displayed on the LCD panel.

---

## Scene file

The unit provides memory to hold data on shooting conditions for 16 different scenes, to enable easy readjustment of the camera for any memorized scenes.

---

## Coordination of settings among several cameras

In a system that includes several cameras that are connected via CCUs, connecting the CCUs allows this unit to set up all of the cameras into the same color condition.

---

## High-precision and high-speed control

Commands can be issued at high speed, which means that remote operation with the unit's knobs can be performed more smoothly than with previous remote control devices. Also, high-precision data transfer raises control precision.

# Location and Function of Parts

## Operation Panel and Connector

The following figure shows external views of this unit.

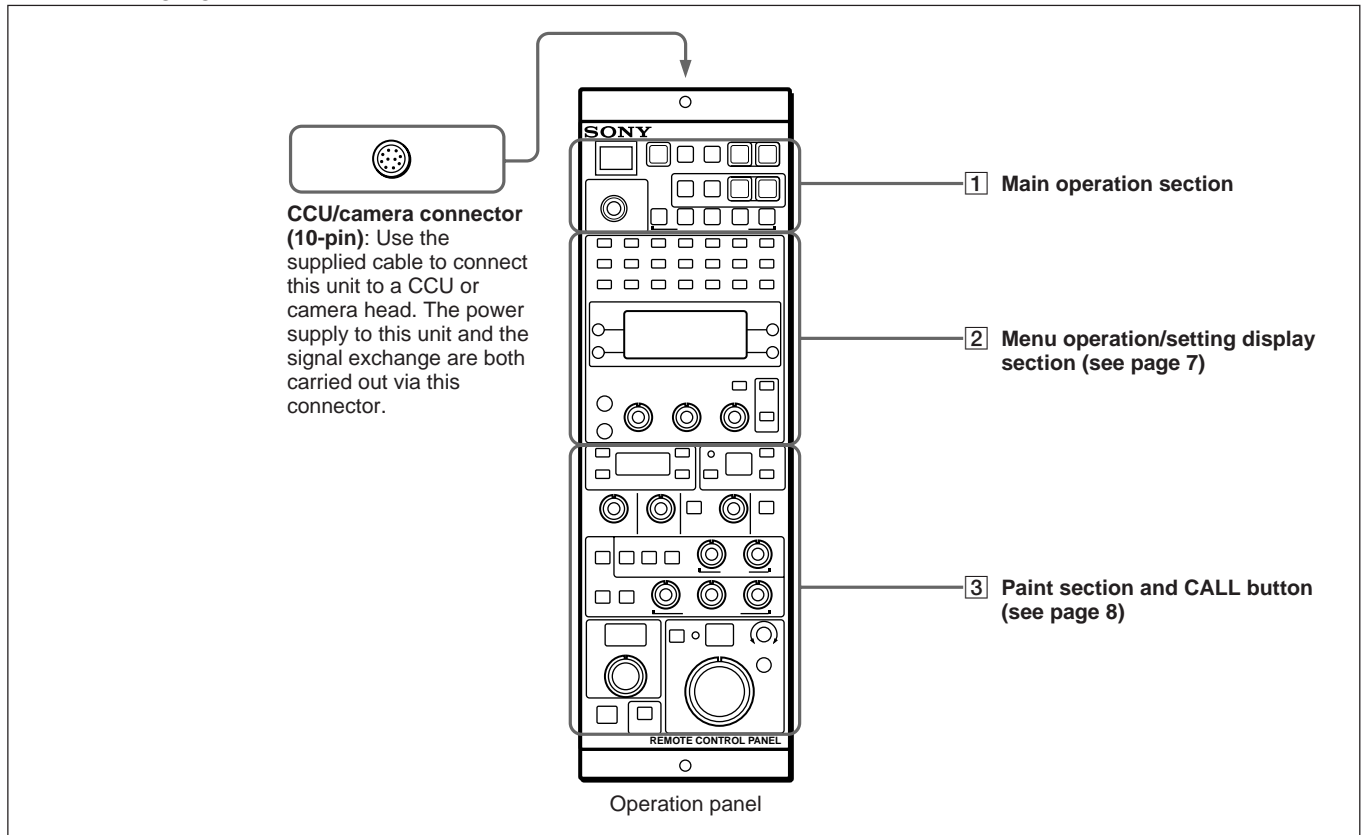

## 1 Main Operation Section

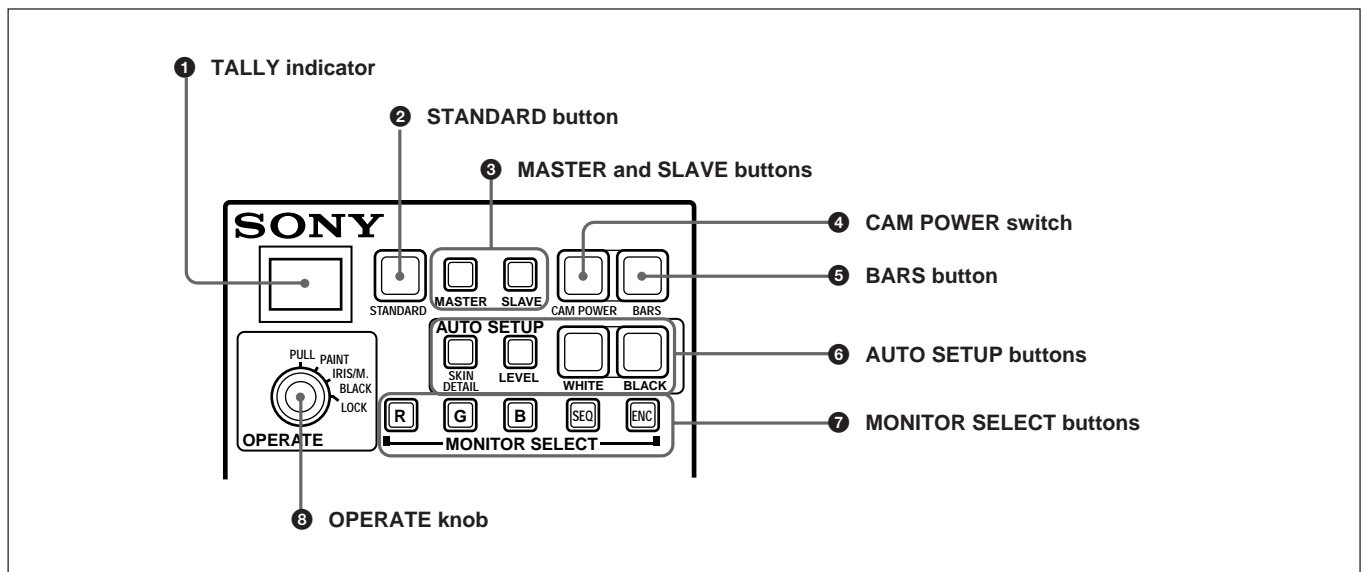

## Location and Function of Parts

### ① TALLY indicator

Lights in red when a red tally signal from the CA or CCU is received and lights in green when a green tally signal is received.

### ② STANDARD button

Press to automatically set up the camera for use under standard shooting conditions.

### ③ MASTER and SLAVE buttons (only when this unit is connected to CCU)

When using several remote control panels connected to CCUs, press the MASTER button on the unit to be used as the master unit and press the SLAVE button on all other units (slave units). Both buttons light when pressed.

Once a unit has been set as the master unit, the MASTER button on any other unit cannot be operated. To select other unit for master unit, press the MASTER button on the current master unit again. (The button goes out.)

For details, see “Multi-Camera Control” on page 26.

### ④ CAM (camera) POWER switch (only when this unit is connected to CCU)

When the power supply is on for the CCU, CA and camera head, this switch lights. You can then turn the power supply for the camera on or off by pressing the switch. The switch lights when the power is on, and goes out when the power is off. It takes a moment until the power is being turned on or off after the switch is pressed. (The switch blinks meanwhile.)

### ⑤ BARS (color bars) button

Press to output color bars from the camera when this unit has been connected to a camera. When this unit has been connected to a CCU, press this button to output color bars from the CCU’s internal color bar generator.

### ⑥ AUTO SETUP buttons

Press one of these buttons to set up the camera automatically for the corresponding item. The buttons will blink when pressed.

Operations of the button are as follows.:

Button	Operation
SKIN DETAIL (only for DXC-D30/D30P)	Recalls the AUTO SKIN menu and performs automatic designation of the skin gate area. <sup>a)</sup>
LEVEL	Performs auto white balance or auto black balance adjustments. (During adjustment, indications appear on the LCD panel in the menu operation/setting display [2].) When using a DXC-D30/D30P, the R/B gamma is set to the standard value.
WHITE	Performs auto white balance adjustment. (During adjustment, indications appear on the LCD panel in the menu operation/setting display [2].)
BLACK	Performs auto black balance adjustment. (During adjustment, indications appear on the LCD panel in the menu operation/setting display [2].)

a) Skin gate area: target color range of skin detail correction or skin matrix adjustment

### ⑦ MONITOR SELECT buttons (only when this unit is connected to CCU)

Press one of these buttons to select the type of signal output via the PIX and WFM connectors on the CCU’s rear panel. The buttons will light when pressed. The following signals can be selected.

Button	Output signal
R	R signal (The G and B signals can be selected at the same time.)
G	G signal (The R and B signals can be selected at the same time.)
B	B signal (The R and G signals can be selected at the same time.)
SEQ	WFM connector: R, G and B sequence signal PIX connector: signal selected last
ENC	Composite video signal

### ⑧ OPERATE knob

Locks some of the buttons and knobs on the control panel.

**FULL:** No locking.

**PAINT:** Locks the buttons and knobs except for those in the paint section [3], CALL button [3], AUTO SETUP buttons ⑥ (excluding LEVEL button) and MONITOR SELECT buttons ⑦.

**IRIS/M.BLACK:** Locks the buttons and knobs except for those in the iris adjustment block and master black adjustment block in the paint section [3], CALL button [3], and MONITOR SELECT buttons ⑦.

**LOCK:** Locks the buttons and knobs except for the CALL button [3] and MONITOR SELECT buttons ⑦.

## 2 Menu Operation/Setting Display Section

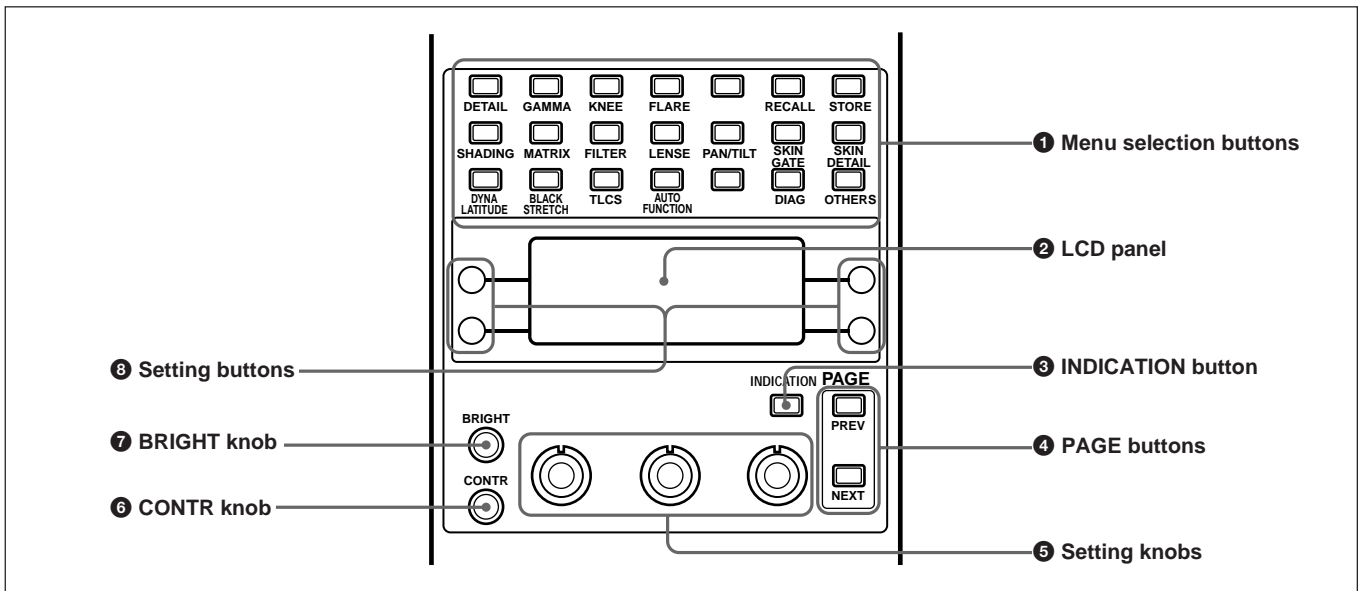

### 1 Menu selection buttons

Press one of these buttons to have the corresponding menu displayed on the LCD panel 2.

For details, see “Basic Menu Operations” page 14.

### 2 LCD panel

Displays menus, messages reporting the progress or results of operations, current settings, etc.

### 3 INDICATION button

Press this button to change indications on the LCD panel in the following order:  
 Current settings of detail level, gamma and knee →  
 Current setting of white balance → Current setting of black balance → Current setting of flare (when the FLARE button in the black balance adjustment/flare correction block is lit) → No indications and back to current settings of detail level, gamma and knee  
 If you press this button while a menu is indicated, the menu indication disappears and then current settings of detail level, gamma and knee appear.

### 4 PAGE buttons

Press the PREV button to display the previous menu page or the NEXT button to display the next menu page. (Each press goes back or forward one page.) Pressing both buttons simultaneously displays the first menu page.

For details, see “Basic Menu Operations” on page 14.

### 5 Setting knobs

Use these knobs to change the settings in various menus.

For details, see “Basic Menu Operations” on page 14.

### 6 CONTR (contrast) knob

Adjusts the contrast of the LCD panel 2 display.

### 7 BRIGHT (brightness) knob

Adjusts the brightness of the LCD panel 2 display.

### 8 Setting buttons

Use these buttons to select functions or settings in various menus.

For details, see “Basic Menu Operations” on page 14.

# Location and Function of Parts

## 3 Paint section and CALL button

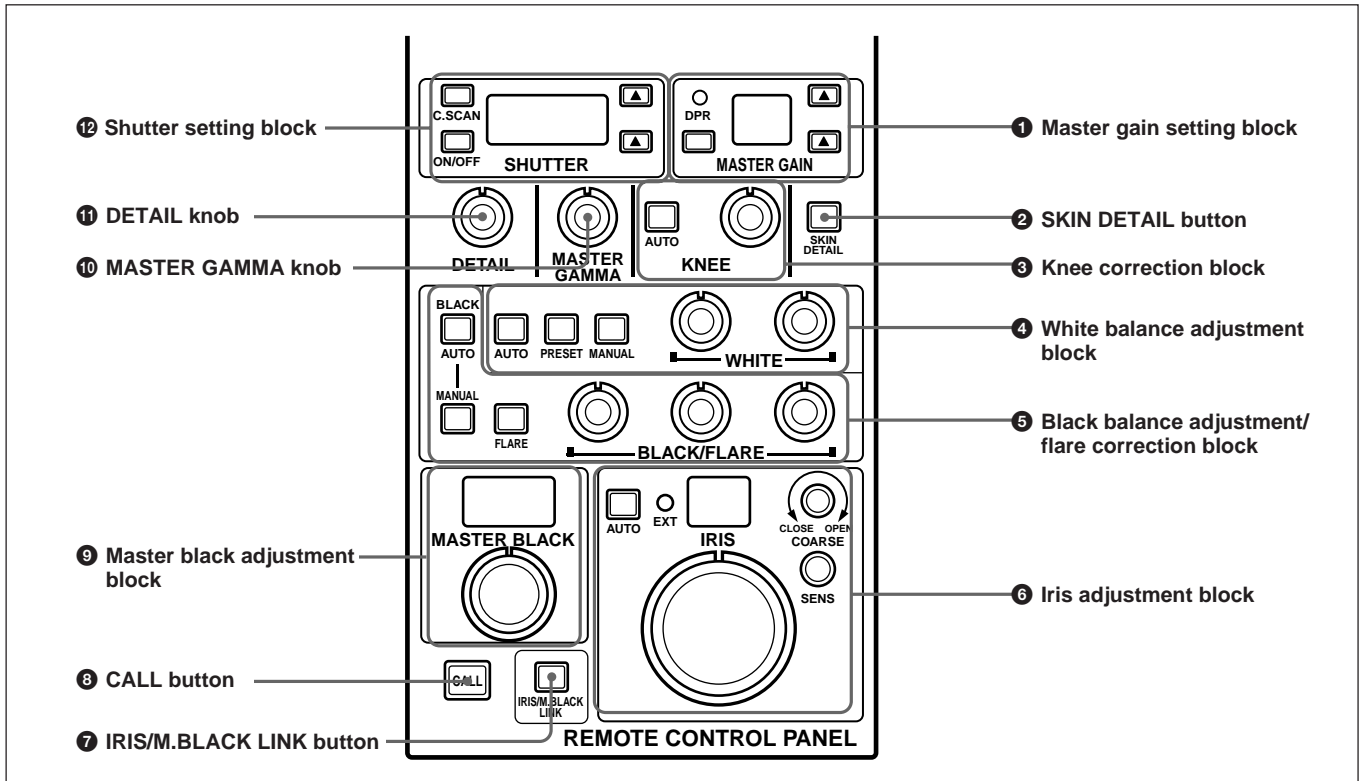

### 1 Master gain setting block

Includes the buttons, a display window, and a DPR indicator described below.

The setting that can be performed via this block differ according to the connected camera.

**When using a DXC-D30/D30P:** Select the gain value from -3, 0, +3, +6, +9, +12, +18, +24 dB, and HYPER GAIN. (HYPER GAIN equals 30 dB + DPR, but the DPR indicator will not light if it is selected.)

**When using a DXC-637 series camera:** Select the gain level from LOW, MID and HIGH. The gain value corresponding to each value is set by camera.

Name	Operation
▲ (up) button	Each press of this button raises the setting value by one step. When using the DXC-D30/D30P, press the up and down buttons simultaneously to set the master gain to 0 dB.
▼ (down) button	Each press of this button lowers the setting value by one step. When using the DXC-D30/D30P, press the up and down buttons simultaneously to set the master gain to 0 dB.
DPR button and indicator	When the master gain is set at 18 or 24 dB, press this button to activate DPR function <sup>a)</sup> .
Display window	Displays the current master gain value.

a) DPR (Dual Pixel Readout) function: When this function is active, CCD output signal readout is performed one pair of two adjacent pixels after another instead of one pixel after another. Sensitivity increases (but resolution decreases) as signal readout take place at a time for the two pixels in each pair.

### 2 SKIN DETAIL button (only when using DXC-D30/D30P)

Press to perform skin detail correction. (The button will light when pressed.)

*For details, see "Skin Detail Correction/Skin Matrix Adjustment (for DXC-D30/D30P Only)" on page 25.*

### ③ Knee correction block

Press the AUTO button to activate the auto knee circuit. The button will light when pressed. However, when the DynaLatitude function is set to on (*see DYNA LATITUDE on page 16*), the auto knee circuit automatically activates and the AUTO button lights. When the AUTO button is not lit and “VARIABLE” is selected in the KNEE menu, you can use the knob in this block to manually adjust the knee point value. To use the preset value, select “PRESET” in the KNEE menu.

*For details of the KNEE menu, see page 15 (for DXC-D30/D30P) or 19 (for DXC-637 series).*

### ④ White balance adjustment block

Use the following buttons and knobs to automatically or manually adjust the white balance. The buttons and knobs operate differently according to the connected camera.

#### When using the DXC-D30/D30P:

Name	Operation
AUTO (auto adjust) button	Press this button (which lights when pressed) to perform automatic white balance adjustment. This button does not operate while the ATW function <sup>a)</sup> is operating. ( <i>See the ATW in the AUTO FUNCTION menu on page 16.</i> )
PRESET button	Press this button (which lights when pressed) to use the preset white balance settings. This button does not operate while the ATW function is operating. ( <i>See the ATW in the AUTO FUNCTION menu on page 16.</i> )
MANUAL button	When this button is pressed and lit, the white balance can be manually adjusted. This button does not operate while the ATW function is operating. ( <i>See the ATW in the AUTO FUNCTION menu on page 16.</i> )
WHITE (white balance) R knob	When the MANUAL button is lit, use this knob to adjust the R signal gain.
WHITE (white balance) B knob	When the MANUAL button is lit, use this knob to adjust the B signal gain.

a) ATW (Auto Tracing White balance) function: This function automatically adjusts the white balance when lighting conditions change.

#### When using the DXC-637 series:

Name	Operation
AUTO (auto adjust) button	Press this button (which lights when pressed) to perform automatic white and black balance adjustments. While the ATW function is operating ( <i>see the ATW in the AUTO FUNCTION menu on page 20</i> ), only automatic black balance adjustment is performed.
PRESET button	Press this button (which lights when pressed) to perform automatic black balance adjustment with using the preset white balance settings. While the ATW function is operating ( <i>see the ATW in the AUTO FUNCTION menu on page 20</i> ), only automatic black balance adjustment is performed.
MANUAL button	When this button is pressed and lit, the white and black balance can be manually adjusted. <sup>a)</sup> The white balance cannot be manually adjusted while the ATW function is operating ( <i>see the ATW in the AUTO FUNCTION menu on page 20</i> ).
WHITE (white balance) R knob	When the MANUAL button is lit, use this knob to adjust the R signal gain.
WHITE (white balance) B knob	When the MANUAL button is lit, use this knob to adjust the B signal gain.

a) To manually adjust the black balance, use the BLACK/FLARE R, G, and B knobs. *See “⑤ Black balance adjustment/flare correction block” on next page.*

## Location and Function of Parts

### ⑤ Black balance adjustment/flare correction block

Use the buttons and knobs described below to perform automatic or manual adjustment of black balance and to perform flare correction.

The buttons and knobs operate differently according to the connected camera.

#### When using the DXC-D30/D30P:

Name	Operation
FLARE button	Press this button (which lights when pressed) to perform flare correction using the BLACK/FLARE knobs when it is allowed in the FLARE menu (see page 15).
BLACK AUTO (black balance auto adjust) button	Press this button (which lights when pressed) to perform automatic black balance adjustments.
BLACK MANUAL (black balance manual adjust) button	When this button is pressed and lit, the black balance can be manually adjusted.
BLACK FLARE R knob	When the BLACK MANUAL button is lit, use this knob to adjust the R signal level. When the FLARE button is lit, use this knob to perform flare correction of the R signal.
BLACK FLARE B knob	When the BLACK MANUAL button is lit, use this knob to adjust the B signal level. When the FLARE button is lit, use this knob to perform flare correction of the B signal.
BLACK FLARE G knob	When the BLACK MANUAL button is lit, use this knob to adjust the G signal level. When the FLARE button is lit, use this knob to perform flare correction of the G signal.

#### When using the DXC-637 series:

Name	Operation
FLARE button	This button does not operate (because manual flare correction is disallowed on the DXC-637 series).
BLACK AUTO (black balance auto adjustment) button	This button does not operate.
BLACK MANUAL (black balance manual adjustment) button	This button does not operate.
BLACK FLARE R knob	When the MANUAL button in the white balance adjustment block ④ is lit, use this knob to adjust the R signal level.
BLACK FLARE B knob	When the MANUAL button in the white balance adjustment block ④ is lit, use this knob to adjust the B signal level.
BLACK FLARE G knob	When the MANUAL button in the white balance adjustment block ④ is lit, use this knob to adjust the G signal level.

### ⑥ Iris adjustment block

Use the following buttons and knobs to automatically or manually adjust the iris setting.

Name	Operation
AUTO (auto adjust) button	Press this button (which lights when pressed) to activate auto iris function.
EXT (extender) indicator	Lights when a lens extender is used. (This indicator does not operate when using the DXC-637 series).
Display window	The current F-stop value is shown in this window. (When using the DXC-637 series, only manual adjustment values are shown.)
IRIS knob	Use this knob to manually adjust the iris when the AUTO button is not lit. When the AUTO button is lit, use this knob to manually adjust the iris override.
COARSE (iris coarse adjust) knob	Use this knob to coarsely adjust the iris when the AUTO button is not lit. If the AUTO button is lit, use this knob to manually adjust the iris override.
SENS (sensitivity adjust) knob	Use this knob to adjust how many rotations of the IRIS knob are required to set the full iris range from open to closed. MIN: About four rotations CENTER: About one rotation MAX: About 1/2 rotation

**7 IRIS/M.BLACK LINK (iris/master black adjustment link) button**

Press this button (which lights when pressed) to perform linked adjustments of iris and master black for several cameras.

*For details, see “Adjusting the Iris and Master Black of Multiple Cameras at One Time” on page 27.*

**8 CALL button**

Press this button (which lights when pressed) to light the CALL button and red tally indicator on the camera, CA, and CCU. This button lights when the unit receives a tally signal from the CA or CCU.

**9 Master black adjustment block**

Use the knob to adjust the master black. During adjustment, adjustment value is shown in the display window here.

**10 MASTER GAMMA knob**

Use this knob to adjust the master gamma. During adjustment, adjustment value is shown on the LCD panel in the menu operation/setting display section **2**.

**11 DETAIL knob**

Use this knob to adjust the master detail. During adjustment, adjustment value is shown on the LCD panel in the menu operation/setting display section **2**.

**12 Shutter setting block**

Use the buttons described below to set the shutter’s operation mode, speed, and CLS (clear scan) frequency.

Name	Operation
C. SCAN (clear scan) button	Press this button (which lights when pressed) to set the CLS frequency. This button does not operate when the TLCS (total level control system) is operating.
SHUTTER ON/OFF button	Press this button (which lights when pressed) to set the shutter speed. This button does not operate when the camera’s TLCS is operating.
▲ (up) button	Each press of this button raises the CLS frequency or shutter speed setting value by one step. (The CLS frequency value changes continuously while the button is being pressed.) Press the up and down buttons simultaneously to select the minimum value.
▼ (down) button	Each press of this button lowers the CLS frequency or shutter speed setting value by one step. (The CLS frequency value changes continuously while the button is being pressed.) Press the up and down buttons simultaneously to select the minimum value.
Display window	Displays the current CLS frequency when the C.SCAN button is lit. Displays the current shutter speed when the ON button is lit.

# Menu Operations

## Displaying menus

Press one of the menu selection buttons to have the corresponding menu displayed in the LCD panel. To access the AUTO SKIN menu (*see pages 17 and 19*), however, press the AUTO SETUP SKIN DETAIL button (*see page 6*).

The menus that correspond to the buttons are listed below.

Most of menus consist of several pages which are divided into two types: normal setting pages and advanced setting pages. This unit is allowed to access only normal setting pages when it is powered on. To access advanced setting pages, follow the procedure described below and set the unit to the advanced setting mode.

## Setting the unit to the advanced setting mode

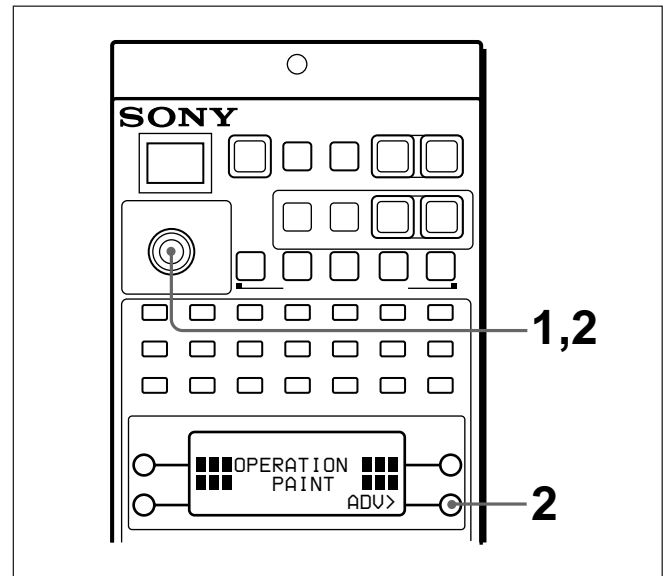

- 1** Set the OPERATE knob to “PAINT”.  
“ADV>” appears on the LCD panel.
- 2** Set the OPERATE knob to “FULL” while pressing down the setting button on the right of the “ADV>” indication.

### Note

During menu operations, the message “ITEM NOT AVAILABLE” appears on the LCD panel under the following situations. Wait until the message disappears and perform correct operations.

- When using the DXC-D30/D30P, trying to access a menu consisting of only advanced setting pages (such as the GAMMA or SHADING menu) without setting the unit to the advanced setting mode
- When using the DXC-637 series, pressing a menu selection button which does not operate for the DXC-637 series (such as the DETAIL button)

Button/menu title	Principle settings		When using DXC-637 series
	When using DXC-D30/D30P		
	Normal settings <sup>a)</sup>	Advanced settings <sup>a)</sup>	
DETAIL	Detail correction-1 (page 15)	<ul style="list-style-type: none"> <li>Detail correction-2 (page 17)</li> <li>Aperture correction (page 17)</li> </ul>	–
GAMMA	–	Gamma correction (page 18)	–
KNEE	Knee correction (page 15)	White clip circuit on/off (page 18)	Knee correction (page 19)
FLARE	Flare correction (page 15)	–	–
RECALL	Recall scene file/setup file (page 15)	–	Recall scene file (page 19)
STORE	Store scene file/setup file (page 15)	–	Store scene file (page 19)
SHADING	–	Shading correction (page 18)	–
MATRIX	<ul style="list-style-type: none"> <li>Matrix adjustment-1 (page 16)</li> <li>Skin matrix adjustment (page 16)</li> </ul>	Matrix adjustment-2 (page 18)	Matrix adjustment mode (page 19)
FILTER	Filter position indication (page 16)	–	–
LENS	Focus/zoom control (page 16)	–	Focus/zoom control (page 20)
PAN/TILT	Pan/tilt operation (page 16)	–	Pan/tilt operation (page 20)
SKIN GATE	Skin gate setting-1 (page 16)	Skin gate setting-2 (page 18)	–
SKIN DETAIL	Skin detail correction (page 16)	–	–
DYNA LATITUDE	DynaLatitude function (page 16)	–	–
BLACK STRETCH <sup>b)</sup>	Black stretch/compress-1 (page 16)	Black stretch/compress-2 (page 18)	–
TLCS (total level control system)	TLCS function (page 16)	–	–
AUTO FUNCTION	<ul style="list-style-type: none"> <li>Auto iris mode (page 16)</li> <li>ATW function (page 16)</li> </ul>	–	<ul style="list-style-type: none"> <li>Auto iris mode (page 20)</li> <li>ATW function (page 20)</li> </ul>
DIAG (diagnosis)	–	Displaying camera self-diagnosis results (page 18)	–
OTHERS	<ul style="list-style-type: none"> <li>EVS/ECS (page 16)</li> <li>Camera ID (page 16)</li> <li>Clock indication (page 17)</li> <li>Center marker (page 17)</li> <li>Safety zone marker (page 17)</li> </ul>	<ul style="list-style-type: none"> <li>Data transfer (page 18)</li> <li>1 kHz-tone signal (page 18)</li> <li>Color bars type (page 18)</li> <li>Screen mode display (page 18)</li> <li>Items set by command link operation (page 19)</li> </ul>	<ul style="list-style-type: none"> <li>EVS (page 20)</li> <li>Title (page 20)</li> <li>Clock indication (page 20)</li> </ul> <p><b>Advanced settings<sup>a)</sup></b></p> <ul style="list-style-type: none"> <li>Data transfer (page 20)</li> <li>Items set by command link operation (page 20)</li> </ul>
AUTO SETUP SKIN DETAIL <sup>c)</sup>	<ul style="list-style-type: none"> <li>Automatic designation of the skin gate (page 17)</li> <li>Skin gate setting-1 (page 17)</li> </ul>	Skin gate setting-2 (page 19)	–

a) When the unit is set to the advanced setting mode, both the normal and advanced settings can be performed.

b) The menu title is “BLACK STR”.

c) This button is not a menu selection button (see ⑥ AUTO SETUP buttons on page 6). The menu title is “AUTO SKIN”.

# Menu Operations

## Basic Menu Operations

### Changing pages

Press a menu selection button to display the first page of the corresponding menu.

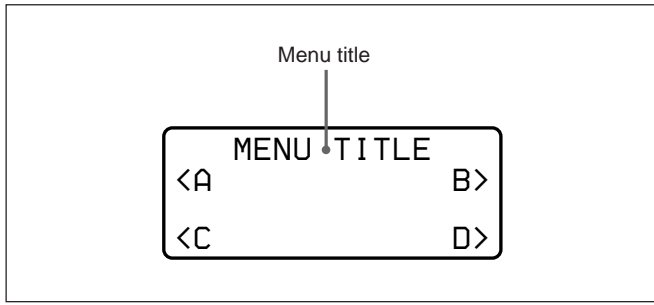

If your desired item is not on the first page, press the NEXT button to go to the next page. You can also change the pages by pressing the menu selection button repeatedly.

To go back one page, press the PREV button.

Pressing both buttons simultaneously recalls the first menu page.

When the unit is set to the advance setting mode (see page 12), the advanced setting pages can be displayed in addition to the normal setting pages.

### Using the knobs and buttons

Three knobs and four buttons are used to make settings via menu operations.

The following figure shows how these knobs and buttons are used.

#### How to use the buttons

Functions of the buttons vary according to menu.

### Example: KNEE menu (KNEE MODE setting page)

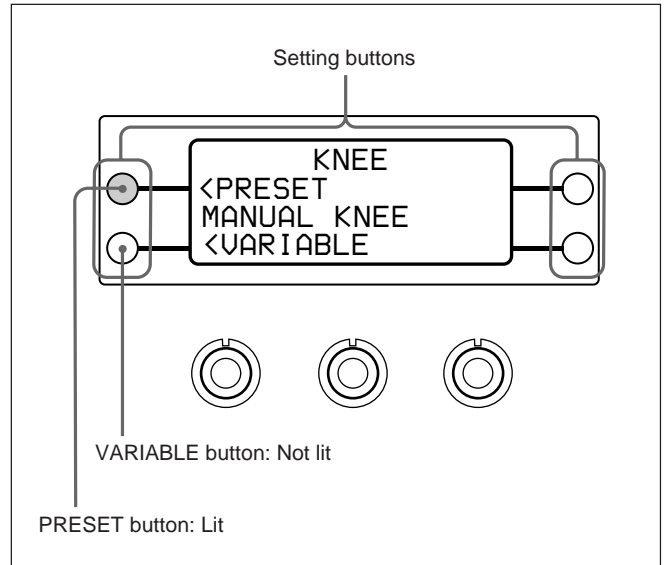

In this case, the upper left button operates as PRESET button, and the lower left button operates as VARIABLE button. The PRESET button is lit because the preset mode is currently selected.

Press the VARIABLE button to select the variable mode.

#### How to use the knobs

Functions of the knobs vary according to menu.

### Example: DETAIL menu

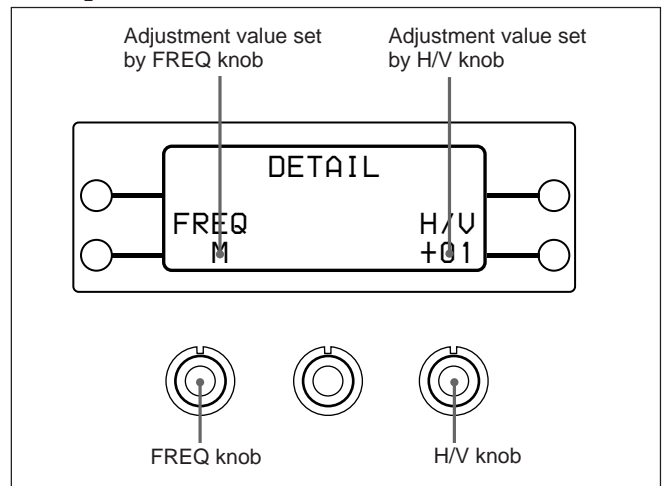

In this case, the left knob operates as FREQ (frequency) knob, and the right knob operates as H/V knob.

To set the frequency, turn the FREQ knob. To set the H/V, turn the H/V knob.

**Note**

The adjustment values displayed on the LCD panel may be relative values (not real values). Slight turn of a knob sometimes causes undesirable sudden change of values.

Even in the case that they are real values, values may change while they are transferred to the camera.

## Menu Contents

The contents of each menu, which vary according to the camera, are listed in the table below.

Menu title	Knob/button	Setting or operation
DETAIL	FREQ knob: LL/M/H/HH	Boost frequency for the detail correction
	H/V knob: -99 to <u>00</u> to 99	Ratio of V (vertical) detail to H (horizontal) detail (As the value becomes larger, the V detail ratio increases.)
KNEE (1/2)	PRESET button	Setting the knee point (level at which the knee correction starts) and knee slope (amount of the knee correction) manually using the preset values ( <i>see page 9</i> ).
	<u>VARIABLE</u> button	Setting the knee point and knee slope manually ( <i>see page 9</i> ). Values can be set by the knob in the knee correction block or the POINT and SLOPE knobs on page 2/2 of the KNEE menu.
KNEE (2/2)	POINT knob: -99 to <u>00</u> to 99	Knee point (As the value becomes larger, the start level lowers, which enhances the knee correction effect.)
	SLOPE knob: -99 to <u>00</u> to 99	Knee slope
FLARE	ON/OFF buttons	Select whether or not you will perform flare correction.
	RED/GREEN/BLUE knobs: -99 to <u>00</u> to 99	Amounts of flare correction for R, G and B signals.
RECALL (1/2) <i>See page 23 for details.</i>	SCENE F. RECALL button	Press to recall a scene file stored in this unit's memory.
	SEL knob: USR01 to USR16	Select a scene file that you will recall.
RECALL (2/2) <i>See page 24 for details.</i>	SETUP F. RECALL button	Press to recall a setup file stored in the camera's memory.
	SEL knob: PRE1 to PRE5 and USR1 to USR3	Select a setup file that you will recall.
STORE (1/2) <i>See page 23 for details.</i>	SCENE F. STORE button	Press to store a scene file onto this unit's memory. Use the SEL knob to number the file.
	CUR knob	Move the cursor to enter a file name (eight characters).
	SEL knob: USR01 to USR16	Select a number for the file that you will store.
	CHR knob:	Select characters to enter a file name.
STORE (2/2) <i>See page 24 for details.</i>	SETUP F. STORE button	Press to store a setup file onto the camera's memory. Use the SEL knob to number the file.
	CUR knob	Move the cursor to enter a file name (eight characters).
	SEL knob: USR1 to USR3	Select a number for the file that you will store.
	CHR knob:	Select characters to enter a file name.

(continued)

## When using the DXC-D30/D30P

The list for the case of using the DXC-637 series is on page 19.

### Normal setting pages

Underlined values or settings are selected at the shipping of the camera.

See page 17 for advanced setting pages.

## Menu Operations

Menu title	Knob/button	Setting or operation
MATRIX (1/2)	ON/OFF buttons	Select whether or not you will perform linear matrix adjustment.
	SAT/HUE knobs: <u>-99</u> to <u>00</u> to +99	Saturation and hue
MATRIX (2/2: SKIN)	ON/OFF buttons	Select whether or not you will perform matrix adjustment of the skin gate area.
	SAT/HUE knob: <u>-99</u> to <u>00</u> to +99	Saturation and hue of the skin gate area
FILTER	–	Displays the current filter position (1, 2, 3, or 4).
LENS <sup>a)</sup>	ON/OFF buttons	Activate optional control function 1 or not.
	FOCUS knob: <u>-99</u> to <u>00</u> to +99	Focus
	ZOOM knob: <u>-99</u> to <u>00</u> to +99	Zoom
PAN/TILT <sup>b)</sup>	ON/OFF buttons	Activate optional control function 2 or not.
	PAN knob: <u>-99</u> to <u>00</u> to +99	Rotation of the tripod head
	TILT knob: <u>-99</u> to <u>00</u> to +99	Tilt of the tripod head
SKIN GATE (1/2)	ON/OFF buttons	Select whether or not you will display the skin gate area (color range designated as skin tone) using the PIX output from the CCU-TX7/7P.
	GATE SIZE knob: <u>-99</u> to <u>00</u> to +99	R–Y and B–Y ranges of the skin gate area (for setting each range to the same value at the same time)
SKIN GATE (2/2: SIZE)	R–Y knob: <u>-99</u> to <u>00</u> to +99	R–Y range of the skin gate area
	B–Y knob: <u>-99</u> to <u>00</u> to +99	B–Y range of the skin gate area
SKIN DETAIL	LEVEL knob: <u>-99</u> to <u>00</u> to +99	Amount of skin detail correction (As the value becomes larger, the detail level lowers.)
DYNA LATITUDE	OFF button	Do not use the DynaLatitude function.
	LOW/MID/Hi buttons	Select the DynaLatitude level.
BLACK STR	LEVEL knob: <u>-99</u> to <u>00</u> to +99	Black stretch level
TLCS	ON/OFF button	Select whether or not you will use the TLCS (total level control system) function.
	AGC knob: F5.6/F4/F2.8/F1.8	F-stop value at which the auto iris control is switched to the AGC (auto gain control)
	GAIN knob: 0/3/6/9/12dB	Upper limit value for the AGC
	AE knob: F5.6/F8/F11/F16	F-stop value at which the auto iris control is switched to the AE (auto exposure).
AUTO FUNCTION (1/2: ATW)	ON/OFF buttons	Select whether or not you will use the ATW (auto tracing white balance) function.
AUTO FUNCTION (2/2: A.IRIS MODE)	STD button	Standard auto iris mode
	SPOT.L button	Auto iris mode for shooting spot-lit subjects
	AI button	Intelligent auto iris mode
	BACK.L button	Auto iris mode for shooting back-lit subjects
OTHERS (1/6: SHUTTER)	EVS button	Set the shutter to the EVS mode. If you do not use the EVS mode, set the C.SCAN button or SHUTTER ON/OFF button to ON in the shutter setting block 12 (see page 11).
OTHERS (2/6: CAM ID SET)	CUR knob	Move the cursor to enter a camera ID (eight characters).
	CHR knob	Select characters to enter a camera ID (alphanumerics, symbols, and space).
OTHERS (3/6: CAM ID IND)	ON/OFF buttons	Select whether or not you will display a camera ID.

Menu title	Knob/button	Setting or operation
OTHERS (4/6: CLOCK IND)	CAM button	Display the date/time.
	<u>OFF</u> button	Do not display the date/time.
	BARS button	Display the date/time only when camera color bars are displayed.
OTHERS (5/6: CENTER MARKER)	<u>ON/OFF</u> buttons	Select whether or not you will display the center marker.
OTHERS (6/6: SAFETY ZONE)	80%/90% buttons	Select safety zone marker size.
	<u>OFF</u> button	Do not display the safety zone marker.
AUTO SKIN <sup>c)</sup>	GATE SIZE knob: -99 to <u>00</u> to +99	R-Y and B-Y ranges of the skin gate area (for setting each range to the same value at the same time)

- a) Lens control requires a focus and zoom servo interface unit (not supplied) and camera adaptor interface unit for lens control (not supplied).
- b) Use an electrical tripod head for remote pan/tilt operation. A camera adaptor interface unit for tripod head control (not supplied) is required.
- c) This menu is recalled with the AUTO SETUP SKIN DETAIL button on page 6.

### Advanced setting pages

For each menu, the advanced setting pages as described below are displayed in addition to the normal setting pages (listed on page 15). In this menu display mode, the page numbering system is serial,

that is, the total number refers to the sum of both normal and advanced setting pages. Underlined values or settings are selected as factory settings for the camera. (Factory settings are otherwise indicated in some menus.)

Menu title	Knob/button	Setting or operation
DETAIL (2/8)	<u>ON/OFF</u> buttons	Select whether or not you will perform detail correction.
DETAIL (3/8)	CRISP knob: -99 to 00 to +99 (Factory setting: -96)	Crispening level (at which details of noise signals are removed)
	LEV DEP knob: -99 to 00 to +99 (Factory setting: 63)	Level dependence (level at which the detail signal starts being suppressed.)
	V-DTL LIMIT knob: -99 to 00 to +99 (Factory setting: -71)	Limit value of the vertical detail
DETAIL (4/8)	HIGHLIGHT knob: -99 to 00 to <u>+99</u>	Highlight detail (amount of detail suppression to highlight areas)
	AFTER GAMMA knob: -99 to 00 to +99 (Factory setting: -71)	Amount of detail added after gamma correction
DETAIL (5/8: APERTURE)	<u>ON/OFF</u> buttons	Select whether or not you will perform aperture correction.
	LEVEL knob: -99 to <u>00</u> to +99	Amount of aperture correction
DETAIL (6/8: KNEE APERTURE)	<u>ON/OFF</u> buttons	Select whether or not you will perform detail correction to the levels higher than the knee point.
	LEVEL knob: -99 to 00 to +99 (Factory setting: 51)	Amount of the detail correction to the levels higher than the knee point.
DETAIL (7/8: CROSS COLOR SUPPRESS)	CROSS COLOR SUPPRESS knob: <u>-99</u> to 00 to +99	Amount of cross color suppression
DETAIL (8/8: COMB FILTER)	RED <u>ON/OFF</u> buttons	Select whether or not you will activate the red comb filter in the detail circuit. If you select OFF, clarity improves but cross color increases.
	GRN <u>ON/OFF</u> buttons	Select whether or not you will activate the green comb filter in the detail circuit. If you select OFF, clarity improves but cross color increases.
GAMMA (1/2)	<u>ON/OFF</u> buttons	Select whether or not you will perform gamma correction.
	RED/BLUE knobs: -99 to <u>00</u> to +99	Amount of R and B gamma
	MAST knob: -99 to <u>00</u> to +99	Amount of master gamma

(continued)

## Menu Operations

Menu title	Knob/button	Setting or operation
GAMMA (2/2: GAMMA INIT GAIN)	3.5/4.0 buttons	Select the slope of the initial part of the gamma curve for low-brightness.
KNEE (3/3: WHITE CLIP)	ON/OFF buttons	Select whether or not you will activate the white clip circuit.
	LEVEL knob: -99 to <u>00</u> to +99	Amount of white clip (As the value becomes larger, the output level lowers.)
SHADING (WHITE V SAW)	RED/GREEN/BLUE knobs: -99 to <u>00</u> to +99	Amount of vertical white shading for R, G and B signals
MATRIX (3/4)	R-G knob: -99 to 00 to +99 (Factory setting: +65 for DXC-D30 or +38 for DXC-D30P)	R-G level of the linear matrix
	B-G knob: -99 to 00 to +99 (Factory setting: +28 for DXC-D30 or +22 for DXC-D30P)	R-B level of the linear matrix
	G-R knob: -99 to 00 to +99 (Factory setting: +31 for DXC-D30 or +12 for DXC-D30P)	G-R level of the linear matrix
MATRIX (4/4)	G-B knob: -99 to 00 to +99 (Factory setting: +32 for DXC-D30 or +15 for DXC-D30P)	G-B level of the linear matrix
	B-R knob: -99 to 00 to +99 (Factory setting: +22 for DXC-D30 or +12 for DXC-D30P)	B-R level of the linear matrix
	B-G knob: -99 to 00 to +99 (Factory setting: +6 for DXC-D30 or +15 for DXC-D30P)	B-G level of the linear matrix
SKIN GATE (3/3)	POSI R-Y/B-Y knobs: -99 to <u>00</u> to +99	R-Y and B-Y levels of the skin gate
BLACK STR (2/3: STRETCH LEVEL)	POINT 1 knob: -99 to 00 to +99 (Factory setting: -39)	Lower limit of the signal levels which activate the black stretch function
	POINT 2 knob: -99 to 00 to +99 (Factory setting: -41)	Upper limit of the signal levels which activate the black stretch function
BLACK STR (3/3: COMPRESS LEVEL)	POINT 1 knob: -99 to 00 to +99 (Factory setting: -77)	Lower limit of the signal levels which activate the black compress function
	POINT 2 knob: -99 to 00 to <u>+99</u>	Upper limit of the signal levels which activate the black compress function
DIAG	RESET button	Reset (erase) the camera's self-diagnosis data.
	REQ button	Press to request camera's self-diagnosis data. If an abnormality has been detected, the data will be transferred to the RCP and displayed. Change the menu page to change data indications. (If there is no abnormality, no data will be displayed.)
OTHERS (2/11: COPY TO SLAVES) <i>For details, see page 27.</i>	COPY TO SLAVES button	Copy the settings of the master unit to the slave units.
OTHERS (8/11: TONE/BARS TYPE)	ON/OFF buttons	Select whether or not you will allow the camera to output a 1-kHz audio signal when color bars are displayed.
	BARS TYPE knob: SMPTE/SNG/FULL FIELD 75%/FULL FIELD 100%(For DXC-D30) or SPLIT/SNG/EBU 75%/EBU 100% (For DXC-D30P)	Select color bars output from the camera (not from the CCU-TX7/7P).
OTHERS (9/11: SCREEN MODE)	-	Display the screen mode (4:3).

Menu title	Knob/button	Setting or operation
OTHERS (10/11: COMM LINK ITEM-1) <i>For details, see page 27.</i>	GAIN button	Activate command link operation of gain setting among several cameras.
	SHUTTER button	Activate command link operation of shutter setting among several cameras.
OTHERS (11/11: COMM LINK ITEM-2) <i>For details, see page 27.</i>	WHITE button	Activate command link operation of manual white balance adjustment among several cameras.
	BLACK button	Activate command link operation of manual black balance adjustment among several cameras.
	FLARE button	Activate command link operation of manual flare correction among several cameras.
AUTO SKIN (2/3) <sup>a)</sup>	<u>ON/OFF</u> buttons	Select whether or not you will display the window specifying the skin gate on the viewfinder screen. (When the AUTO SKIN menu is recalled, the ON button is automatically selected.)
	HI-POSI knob: <u>-99</u> to <u>00</u> +99	Horizontal position of the window
	V-POSI knob: <u>-99</u> to <u>00</u> +99	Vertical position of the window
AUTO SKIN (3/3) <sup>a)</sup>	<u>ON/OFF</u> buttons	Select whether or not you will display the window specifying the skin gate on the viewfinder screen. (When the AUTO SKIN menu is recalled, the ON button is automatically selected.)
	WIDTH knob: <u>-99</u> to <u>00</u> +99	Width of the window
	HEIGHT knob: <u>-99</u> to <u>00</u> +99	Height of the window

a) This menu is recalled with the AUTO SETUP SKIN DETAIL button on page 6.

## When using the DXC-637 series

Only the OTHERS menu contains the advanced setting pages.

Underlined values or settings are selected at the shipping of the camera.

Menu title	Knob/button	Setting or operation
KNEE (1/2)	PRESET button	Setting the knee point (level at which the knee correction starts) manually using the preset values ( <i>see page 9</i> ).
	<u>VARIABLE</u> button	Setting the knee point manually ( <i>see page 9</i> ). A value can be set by the knob in the knee correction block or the MANUAL KNEE knob on page 2/2 of the KNEE menu.
KNEE (2/2)	MANUAL KNEE knob: <u>-99</u> to <u>00</u> to +99	Knee point (As the value becomes larger, the start level lowers, which enhances the knee correction effect.)
RECALL <i>See page 23 for details.</i>	SCENE F. RECALL button	Press to recall a scene file stored in this unit's memory.
	SEL knob: <u>USR01</u> to <u>USR16</u>	Select a scene file that you will recall.
STORE <i>See page 23 for details.</i>	SCENE F. STORE button	Press to store a scene file onto this unit's memory. Use the SEL knob to number the file.
	<u>CUR</u> knob	Move the cursor to enter a file name (eight characters).
	SEL knob: <u>USR01</u> to <u>USR16</u>	Select a number for the file that you will store.
	<u>CHR</u> knob:	Select characters to enter a file name.
MATRIX	<u>STD/FL/H.SAT</u> buttons	Select color matrix adjustment mode. STD: standard FL: for shooting under fluorescent lighting H.SAT: high saturation (increasing the saturation of primary colors)

(continued)

## Menu Operations

Menu title	Knob/button	Setting or operation
LENS <sup>a)</sup>	ON/OFF buttons	Activate optional control function 1 or not.
	FOCUS knob: -99 to 00 to +99	Focus
	ZOOM knob: -99 to 00 to +99	Zoom
PAN/TILT <sup>b)</sup>	ON/OFF buttons	Activate optional control function 2 or not.
	PAN knob: -99 to 00 to +99	Rotation of the tripod head
	TILT knob: -99 to 00 to +99	Tilt of the tripod head
AUTO FUNCTION (1/2: ATW)	ON/OFF buttons	Select whether or not you will use the ATW (auto tracing white balance) function.
AUTO FUNCTION (2/2: A.IRIS MODE)	STD button	Standard auto iris mode
	SPOT.L button	Auto iris mode for shooting spot-lit subjects
	BACK.L button	Auto iris mode for shooting back-lit subjects
OTHERS (1/3: EVS)	EVS button	Set the shutter to the EVS mode. If you do not use the EVS mode, set the C.SCAN button or SHUTTER ON/OFF button to ON in the shutter setting block 12 (see page 11).
OTHERS (2/3: TITLE IND)	ON/OFF buttons	Select whether or not you will display the title set on the camera.
OTHERS (3/3: CLOCK IND)	ON/OFF buttons	Select whether or not you will display the date and time.

a) Lens control requires a focus and zoom servo interface unit (not supplied) and camera adaptor interface unit for lens control (not supplied).

b) Use an electrical tripod head for remote pan/tilt operation. A camera adaptor interface unit for tripod head control (not supplied) is required.

### Advanced setting pages (OTHERS menu)

The following advanced setting pages are displayed in addition to the normal setting pages. In this menu

display mode, the page numbering system is serial, that is, the total number refers to the sum of both normal and advanced setting pages.

Menu title	Knob/button	Setting or operation
OTHERS (4/6: COPY TO SLAVES) <i>For details, see page 27.</i>	COPY TO SLAVES button	Copy the settings of the master unit to the slave units.
OTHERS (5/6: COMM LINK ITEM-1) <i>For details, see page 27.</i>	GAIN button	Activate command link operation of gain setting among several cameras.
	SHUTTER button	Activate command link operation of shutter setting among several cameras.
OTHERS (6/6: COMM LINK ITEM-2) <i>For details, see page 27.</i>	WHITE button	Activate command link operation of manual white balance adjustment among several cameras.
	BLACK button	Activate command link operation of manual black balance adjustment among several cameras.

# File Operations

This unit can operate two types of files: scene files and setup files.

Setting data of cameras can be registered as scene files or setup files and recalled as required. (For the DXC-

637 series camera, only scene files are available.)

The table below shows the setting items which can be registered as either of the files.

Setting item	DXC-D30/D30P		DXC-637 series
	Setup file	Scene file	Scene file
Selecting shooting picture or color bars		OK	OK
Master black	OK	OK	OK
Iris		OK	OK
Auto iris mode		OK	OK
Master gain		OK	OK
TLCS		OK	
Upper limit value for AGC		OK	
Initial F-stop value for AGC		OK	
Initial F-stop value for AE		OK	
Shutter/Clear scan		OK	OK
Shutter speed		OK	OK
Clear scan frequency		OK	OK
Filter position		OK	
Selecting white balance or black balance adjustment	OK	OK	
ATW on/off		OK	OK
R/B white balance adjustment		OK	OK
R/B black balance adjustment		OK	OK
Flare correction on/off		OK	
R/G/B flare correction		OK	
Detail correction on/off		OK	
Detail level	OK	OK	OK
Detail boost frequency	OK	OK	
Crispening level	OK	OK	
Level dependence value	OK	OK	
Detail H/V	OK	OK	
V-detail limit value	OK	OK	
Highlight detail	OK	OK	
After gamma detail	OK	OK	
Aperture correction on/off		OK	
Aperture correction value	OK	OK	
Knee aperture correction on/off		OK	
Knee aperture correction value	OK	OK	
Cross color suppress value	OK	OK	
R/G comb filter on/off	OK	OK	
Knee correction mode		OK	OK
Master knee point	OK	OK	OK
Master knee slope	OK	OK	
White clip circuit on/off		OK	
White clip value		OK	
Gamma correction on/off		OK	

(continued)

## File Operations

Setting item	DXC-D30/D30P		DXC-637 series
	Setup file	Scene file	Scene file
Master gamma	OK	OK	
R/B gamma		OK	
Gamma initial gain	OK	OK	
Black stretch level	OK	OK	
Upper/lower limit value for black stretch	OK	OK	
Upper/lower limit value for black compress	OK	OK	
DynaLatitude effect		OK	
Matrix adjustment on/off		OK	
Saturation/hue	OK	OK	
Matrix adjustment mode			OK
Matrix parameter (R-G, R-B, G-R, G-B, B-R, B-G)	OK	OK	
Skin detail level		OK	
Skin matrix saturation/hue	OK	OK	
Skin gate position/size		OK	
Position/size of skin gate detect window		OK	
Focus/zoom		OK	OK
Pan/tilt		OK	OK
On/off selection of optional control 1 or 2		OK	OK

## Operating Scene Files

Scene files are stored in the memory of the RCP. Perform the following procedure to recall or store scene files.

### Recalling a scene file

Use the RECALL menu in the following way.

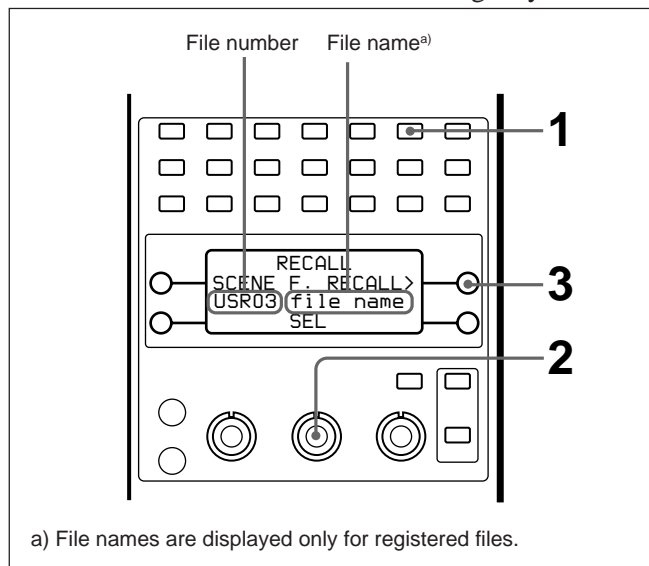

- 1** Press the RECALL button to access the RECALL menu.
- 2** Turn the SEL knob to search the number (USR01 to USR16) of the file which you will recall.

If the selected file is one of the registered files, the file name appears on the right of the file number.

- 3** Press the SCENE F. RECALL button.

The settings of the camera are replaced by the data of the recalled file.

#### Note

If you recall an unregistered file, it is impossible to assure whether the camera will be set up correctly or not. Recall a file once registered.

### Storing a scene file

Use the STORE menu in the following way.

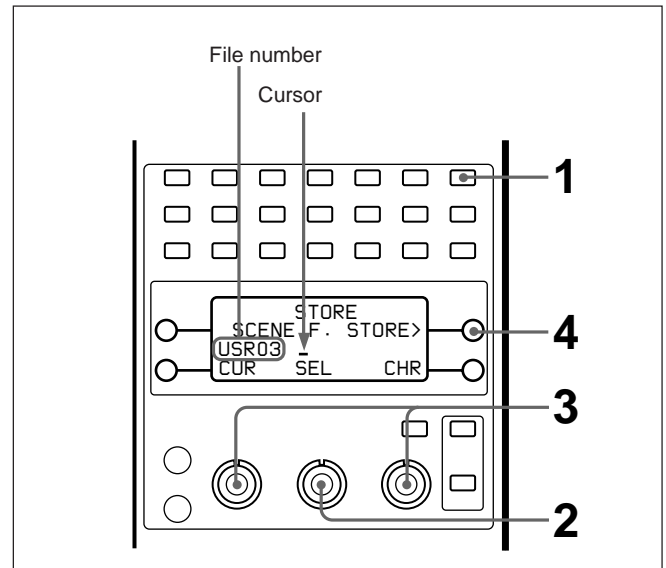

- 1** Press the STORE button to access the STORE menu.
- 2** Turn the SEL knob and select a file number (USR01 to USR16) which you will apply to the current settings of the camera.

A cursor appears on the right of the number. If the selected number has already been used for another data, a file name also appears.

- 3** Enter a file name (eight characters).  
**Moving the cursor:** Turn the CUR knob until the cursor comes to the position where you will enter a character.  
**Selecting a character:** Turn the CHR knob until a character which you will enter appears.

- 4** Press the SCENE F. STORE button.

The current settings of the camera are stored as a scene file.

# File Operations

## Operating Setup Files (for DXC-D30/D30P only)

Setup files are stored in the memory of the camera. Perform the following procedure to recall or store setup files.

### Recalling a setup file

Use the RECALL menu in the following way.

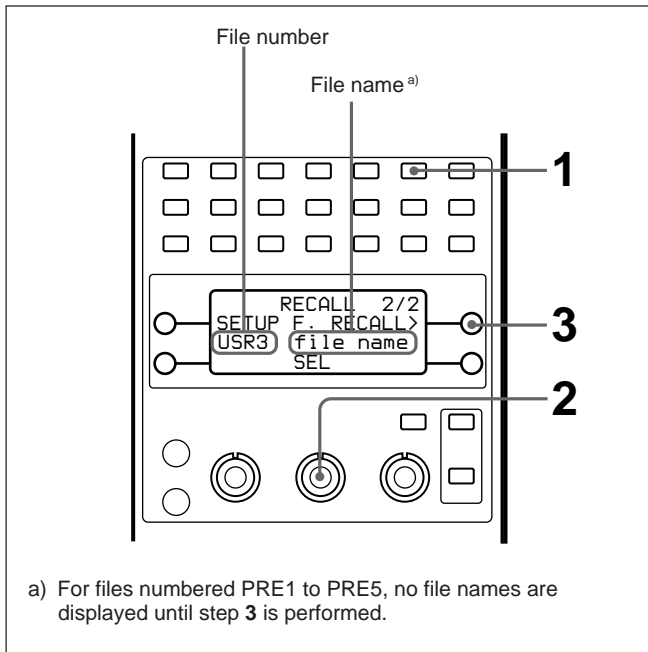

- 1 Press the RECALL button to access the RECALL menu (page 2/2).
- 2 Turn the SEL knob to search the number and name of the file which you will recall. Preset files 1 to 5 (PRE1 to PRE5) and user setup files 1 to 3 (USR1 to USR3) are available.
- 3 Press the SETUP F. RECALL button.

The settings of the camera are replaced by the data of the recalled file.

### Storing a setup file

Use the STORE menu in the following way.

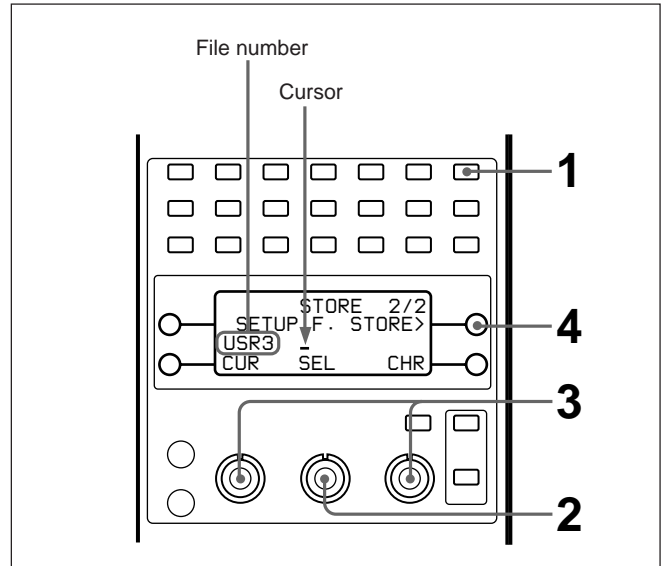

- 1 Press the STORE button to access the STORE menu (page 2/2).
- 2 Turn the SEL knob and select a file number (USR1 to USR3) which you will apply to the current settings of the camera.

A cursor appears on the right of the number. If the selected number has already been used for another data, a file name also appears.

- 3 Enter a file name (eight characters).  
**Moving the cursor:** Turn the CUR knob until the cursor comes to the position where you will enter a character.  
**Selecting a character:** Turn the CHR knob until a character which you will enter appears.
- 4 Press the SETUP F. STORE button.

The current settings of the camera are stored as a setup file.

# Skin Detail Correction/Skin Matrix Adjustment (for DXC-D30/D30P Only)

The skin detail and skin matrix functions can adjust detail level and matrix (saturation and hue) of a selected skin gate area (area designated by color range).

Once a skin gate area has been selected, it can be used as a target for both skin detail correction and skin matrix adjustment, and activation of each function can be performed independently.

---

## Selecting the skin gate area

Normally, use the AUTO SETUP SKIN DETAIL button (*see page 6*) to designate the skin gate position (target color) automatically.

- 1 Press and set the AUTO SETUP SKIN DETAIL button to on.

The AUTO SKIN menu appears on the LCD panel, and the window which shows the skin gate and target area appears in the camera's viewfinder. You can see the skin gate with a picture output from the CCU's PIX connector.

- 2 Press the AUTO SETUP SKIN DETAIL button again.

The skin gate is designated automatically. You can manually adjust the position of the designated skin gate in the SKIN GATE menu (page 3/3, advanced setting page)

- 3 Set the size of the skin gate area (target color range) manually using the SKIN GATE menus if necessary.

**Using page 1/3 of the AUTO SKIN or of the SKIN GATE menu:** You can adjust the R–Y and B–Y ranges to the same value at the same time.

**Using page 2/3 of the SKIN GATE menu:** You can adjust the R–Y and B–Y ranges independently.

---

## Performing skin detail correction

By skin detail correction, you can lower the detail level of the skin gate area to the detail level outside of the area.

- 1 Press and set the SKIN DETAIL button to on (*see page 8*).

- 2 Use the LEVEL knob in the SKIN DETAIL menu to set the detail correction level.

**Setting the level to the max. value (+99):** The detail level of the area is set to the lowest level.

**Setting the level to the min. value (–99):** The detail level of the area is set to the same level with the outside of the area. (The same situation as the skin detail function is set to off.)

If you power off the unit or store the current settings as a scene file while setting the detail level to –99, the skin detail function will be set to off when you power on the unit or recall the scene file next time.

### To store the skin detail settings

Set the SKIN DETAIL button on before powering off the unit or storing the settings as a scene file. If the button is off, the skin detail settings will not be stored.

---

## Performing skin matrix adjustment

Follow the procedure described below to adjust the matrix (saturation and hue) of the skin gate area.

- 1 Select the ON button on both pages 1/2 and 2/2 of the MATRIX menu.  
(Be sure to activate the matrix adjustment function on page 1/2.)

- 2 Use the SATURATION and HUE knobs in page 2/2 of the MATRIX menu to adjust the saturation and hue.

Selecting 00 causes the same situation as the skin matrix function is set off.

If you power off the unit or store the current settings as a scene file while selecting 00, the skin matrix function will be set to off when you power on the unit or recall the scene file next time.

### To store the skin matrix settings

Activate both the matrix adjustment and skin matrix adjustment functions before powering off the unit or storing the settings as a scene file. Otherwise, the skin matrix settings will not be stored.

# Multi-Camera Control

In a multi-camera system, connecting all the CCUs via the RS232C connectors allows one RCP unit selected from all the RCP units in the system to control the multiple cameras.

If the selected unit is set as the master unit and the rest are set as slave units, the setting data of the camera connected to the master unit can be transferred to other cameras.

## To make connections among the CCUs

Connect RS-232C cross (or reverse) cables with D-sub 25-pin plugs (not supplied) to the RS232C connectors on each CCU to make a daisy chain of the CCUs.

*For more information about cables which can be used, consult your Sony dealer.*

### Notes

- It is impossible to assure that all the cameras can be set up to the same conditions under the multi-camera control. Setting purposes and the current condition of each camera may cause variation of the setting condition.
- In a system which contains more than two types of cameras, the setting items, adjustment range and adjustment accuracy available at the multi-camera operation are determined depending on the efficiency of the camera connected to the master unit.
- There are two setting modes: Absolute mode and relative mode.
- Settings performed on a slave unit are valid only to the connected camera.

## Setting a unit to the master unit or a slave unit

### Note

Perform the following procedure after making sure all the cameras in the system are powered on. Note that executing the procedure when there is any cameras powered off may result in failure.

- 1** Select one RCP unit for the master unit, and press the MASTER button. (The button lights when pressed.)
- 2** Select one RCP unit (or more) for a slave unit, and press the SLAVE button. (The button lights when pressed.)

## Operating Multiple Cameras from One RCP Unit —Command Link

Command link allows one RCP selected as the master unit to control the adjustments or settings of the cameras connected to the slave units.

### To perform command link adjustments/ settings

The following table shows the adjustments or settings which can be performed by command link. Perform a listed operation before the desired adjustment or setting on the master unit.

Other than the adjustment or setting listed in the table, iris and master black can be adjusted by command link in a different way.

*For iris and master black adjustments, see “Adjusting the Iris and Master Black of Multiple Cameras at One Time” on next page.*

Adjustments/Settings	To perform command link operation
Gain setting <sup>a)</sup> (absolute mode)	Select the GAIN button on the COMM LINK ITEM-1 page in the OTHERS menu on the master unit.
Shutter setting (absolute mode) <ul style="list-style-type: none"> <li>• Shutter on/off</li> <li>• Clear scan mode on/off</li> <li>• Shutter speed</li> <li>• Clear scan frequency</li> </ul>	Select the SHUTTER button on the COMM LINK ITEM-1 page in the OTHERS menu on the master unit.
R/B manual white balance adjustment <sup>b)</sup> (relative mode)	Select the WHITE button on the COMM LINK ITEM-2 page in the OTHERS menu on the master unit.
R/B manual black balance adjustment <sup>b)</sup> (relative mode)	Select the BLACK button on the COMM LINK ITEM-2 page in the OTHERS menu on the master unit.
R/G/B manual flare correction <sup>b), c)</sup> (relative mode)	Select the FLARE button on the COMM LINK ITEM-2 page in the OTHERS menu on the master unit.

a) Do not perform command link operation in a system containing both the DXC-D30/D30P and DXC-637 series. If the camera connected to a slave unit is different in type from the camera connected to the master unit, changing the gain value on the master unit will set the gain value of the camera connected to the slave unit to 0 dB or the LOW position.

b) Select the manual adjustment mode also on slave units.

c) For DXC-D30/D30P only

## Adjusting the Iris and Master Black of Multiple Cameras at One Time

For iris and master black adjustments, you can use any one of the RCP units (whether it is the master unit or a slave unit) specified with the IRIS/M.BLACK LINK button.

- 1 Select the cameras for which you will adjust the iris or master black by pressing the IRIS/M.BLACK LINK buttons on the connected RCP units. (The buttons light when pressed.)
- 2 Adjust the iris or master black on one RCP unit whose IRIS/M.BLACK LINK button lights.

On the cameras connected to the RCP units whose IRIS/M.BLACK LINK buttons light, the iris or master black adjustments are performed by the same amount and at the same time (on relative mode).

## Data Transfer Among Multiple Cameras

The settings made on the master unit can be transferred to the cameras connected to the slave units, if they can be registered as a scene file (*see page 21*). Perform as follows.

Press the COPY TO SLAVES button on the COPY TO SLAVES page in the OTHERS menu on the master unit.

Data transfer begins.

Meanwhile, on all the linked RCP units (including units selected as neither the master unit nor slave units), the message “COPY IN PROGRESS” is displayed on the LCD panels and all buttons and knobs are locked.

When the data transfer completes, the message “COPY COMPLETED” appears on the LCD panels. The LCD panel soon returns to the original status.

# Specifications

Power supply	10 to 17 V (supplied from camera or CCU)
Power consumption	4.0 W
Operating temperature	-10°C to +45°C (14°F to 113°F)
Storage temperature	-20°C to +55°C (-4°F to +131°F)
External dimensions	100 × 300 × 50 mm (4 × 11 <sup>7</sup> / <sub>8</sub> × 2 inches)
Weight	1.1 kg (2 lb 6 oz)
Maximum cable length	50 m (164 feet)
Data transfer method	New protocol complied with RS-232C
Accessories	Number plates (1 set) Screws (+4 × 8, 2) Washers (2) Cable (1) Operating instructions (1)

Design and specifications are subject to change without notice.