

# *Color Video Camera*

---

## **Operating Instructions**

Before operating the unit, please read this manual thoroughly and retain it for future reference.

## **Power HAD**

**DXC-327BK/BL/BH/BF**

**DXC-327BPK/BPL/BPH/BPF**

# WARNING

**To prevent fire or shock hazard, do not expose the unit to rain or moisture.**

**To avoid electrical shock, do not open the cabinet. Refer servicing to qualified personnel only.**

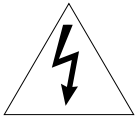
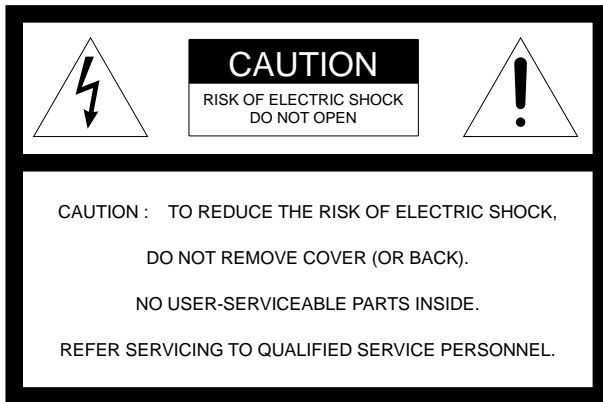

This symbol is intended to alert the user to the presence of uninsulated “dangerous voltage” within the product’s enclosure that may be of sufficient magnitude to constitute a risk of electric shock to persons.



This symbol is intended to alert the user to the presence of important operating and maintenance (servicing) instructions in the literature accompanying the appliance.

## Owner’s Record

The model and serial numbers are located on the right side. Record these numbers in the spaces provided below. Refer to them whenever you call your Sony dealer regarding this product.

Model No. \_\_\_\_\_ Serial No. \_\_\_\_\_

### For the customers in the U.S.A.

This equipment has been tested and found to comply with the limits for a Class A digital device, pursuant to Part 15 of the FCC Rules. These limits are designed to provide reasonable protection against harmful interference when the equipment is operated in a commercial environment. This equipment generates, uses, and can radiate radio frequency energy and, if not installed and used in accordance with the instruction manual, may cause harmful interference to radio communications. Operation of this equipment in a residential area is likely to cause harmful interference in which case the user will be required to correct the interference at his own expense.

You are cautioned that any changes or modifications not expressly approved in this manual could void your authority to operate this equipment.

The shielded interface cable recommended in this manual must be used with this equipment in order to comply with the limits for a digital device pursuant to Subpart B of Part 15 of FCC Rules.

# Table of Contents

<b>Introduction .....</b>	<b>4</b>	<b>Adjustment and Settings .....</b>	<b>46</b>
Composition of the DXC-327B-series Color Video Camera .....	4	Reading Indications in the Electronic Viewfinder .....	46
Choosing from NTSC or PAL System .....	5	Reading the Viewfinder Screen Display Menu ..	49
Notes on Using Accessories with the DXC-327B Series Camera .....	5	Adjusting the Viewfinder Screen Display .....	50
<b>Precautions .....</b>	<b>6</b>	Adjusting the Video Monitor .....	51
On Using and Storing the Camera .....	6	Adjusting the Iris .....	52
Managing Hyper-Sensitivity in the CCD Image Sensor .....	6	Selecting the Filter .....	54
<b>Features .....</b>	<b>7</b>	Adjusting the Black Balance .....	54
<b>Location and Function of Parts .....</b>	<b>8</b>	Adjusting the White Balance .....	56
DXC-327B/327BP Camera Head .....	8	Adjusting the Contrast .....	58
CA-537/537P Camera Adaptor (optional) .....	16	Selecting the Shutter Speed .....	59
VCL-714BX Zoom Lens .....	18	<b>Advanced Operations .....</b>	<b>60</b>
DXF-601/601CE Electronic Viewfinder .....	20	Zoom Operation .....	60
<b>Accessory Attachment .....</b>	<b>22</b>	Adjusting Flange Focal Length .....	61
Attaching/Detaching a Camera Adaptor .....	22	Doing Close-Ups .....	62
Attaching a Videocassette Recorder .....	24	Adjusting the Sharpness of the Picture .....	63
Attaching the Zoom Lens and Optional Filter ...	25	Selecting the Output Level .....	64
Attaching and Adjusting the Electronic Viewfinder .....	27	Checking the Video Level .....	64
Attaching a Microphone .....	29	Synchronizing Two or More Cameras (Without Using a Camera Control Unit) .....	65
Attaching/Detaching a Tripod .....	31	Title Characters Setting .....	67
<b>Connections .....</b>	<b>32</b>	Connecting a Number of Cameras (Using a Camera Control Unit) .....	70
Connecting an S-VHS Format Portable VTR ...	32	<b>Using the Optional Carrying Case .....</b>	<b>71</b>
Connecting a Portable VTR .....	33	<b>Specifications .....</b>	<b>72</b>
Connecting an External Microphone .....	33	Camera Head DXC-327B/327BP .....	72
Connecting a Table-Top VTR .....	34	Camera Adaptor .....	73
Connecting a Camera Control Unit .....	34	CA-537/537P (Optional) .....	73
Connecting a Remote Control Unit .....	36	Zoom Lens VCL-714BX .....	73
Using the Camera with a VTR .....	37	Viewfinder DXF-601/601CE .....	73
<b>Power Sources .....</b>	<b>39</b>	Carrying Case LC-421 .....	73
Using a DC Power Supply .....	39	Accessories Supplied .....	73
Using a Battery Pack .....	40	<b>Optional Accessories and Recommended     Equipment .....</b>	<b>74</b>
Using Power Supplied Through the Camera Adaptor .....	42	<b>Sample Video System Configuration .....</b>	<b>75</b>
<b>Basic Operations .....</b>	<b>43</b>	<b>Glossary .....</b>	<b>76</b>
Operating the Camera .....	43	<b>Index .....</b>	<b>77</b>
Recording with a Portable VTR .....	44		
Recording with a Table-Top VTR .....	44		
Monitoring the VTR Picture and Audio Output	45		

# Introduction

## Composition of the DXC-327B-series Color Video Camera

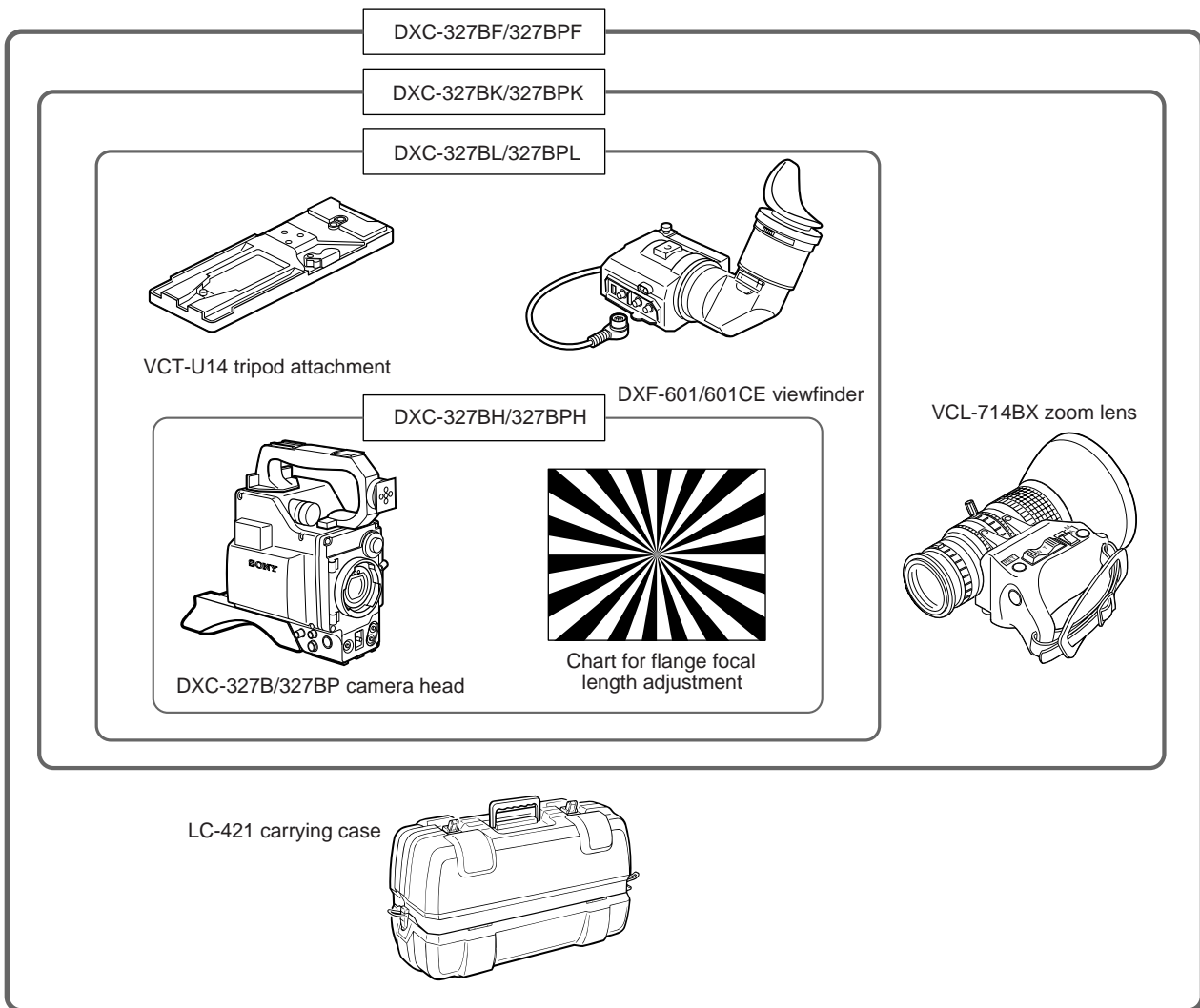

Composition	Model			
	DXC-327BK/327BPK	DXC-327BL/327BPL	DXC-327BH/327BPH	DXC-327BF/327BPF
DXC-327B/327BP camera head		Yes	Yes	Yes
VCL-714BX zoom lens	Yes	No	No	
DXF-601/601CE viewfinder		Yes		
LC-421 carrying case	No	No		
VCT-U14 tripod attachment		Yes	Yes	
Chart for flange focal length adjustment	Yes			

## Choosing from NTSC or PAL System

The following explains the differences between the NTSC and PAL system regarding accessory selection for the DXC-327B series camera.

Some PAL components can operate on NTSC equipment and vice-versa. In general, however, this is not the case. You must use the type of equipment and accessories that matches the signal system of your camera. Use the DXC-327B-series camera within the NTSC color system, and use the DXC-327BP series camera within the PAL system.

## Notes on Using Accessories with the DXC-327B Series Camera

- If you use the CA-537/537P Camera Adaptor (not supplied) with this camera, operate the camera according to the instructions in this manual.
- If you use the CA-327/327P Camera Adaptor (not supplied), operate the camera according to the instructions that come with the adaptor.
- If you use a zoom lens other than the VCL-714BX zoom lens, operate the camera according to the instructions that come with the lens. (For further information on accessories, see “Optional Accessories and Recommended Equipment”, on page 74.)

# Precautions

## On Using and Storing the Camera

This section explains how to safely use, store and clean the camera.

### When setting up the camera

- Do not attach the zoom lens without reading “Attaching the Zoom Lens and Optional Filter” on page 25. Attaching the lens incorrectly may damage the lens.
- Do not directly connect the camera to an AC power line. Use the recommended camera adaptor or use a 12 volt DC power source.
- Do not block air circulation about the camera to prevent internal heat build-up.

### When operating the camera

- Avoid rough handling or mechanical shock.
- Avoid strong magnetic fields to prevent signal distortion.
- Avoid operating the camera in environments that exceed the temperature range of  $-5^{\circ}\text{C}$  to  $+45^{\circ}\text{C}$  ( $23^{\circ}\text{F}$  to  $113^{\circ}\text{F}$ ).
- Do not grip the camera by the viewfinder.

### When using a supplied viewfinder

Do not leave the viewfinder so that sunlight can enter the eyepiece lens. It is possible for sunlight focused by the eyepiece to cause very high temperatures, and melt the inside of the viewfinder

### When storing and shipping the camera

- Cover the lens with the supplied lens cap when you do not plan to use the video camera for an extended period of time.
- When you transport the camera, repack it as it was originally shipped. Do not discard the packing carton. This affords maximum protection whenever you ship the camera. Do not ship or transport the camera in the carrying case alone.
- Store the camera with the viewfinder moved fully in the direction opposite the viewfinder barrel and the lock ring tightened. (See page 28.)

### When cleaning the camera

- Clean the cabinet, panel and controls with a soft, dry cloth or a cloth moistened with a mild detergent solution.
- Do not use any type of solvent, such as alcohol or benzene which might damage the finish.

If you have any questions about this camera, contact your authorized Sony dealer.

## Managing Hyper-Sensitivity in the CCD Image Sensor

Because of the high sensitivity of the CCD image sensors, the following phenomena may appear on the monitor screen while you are using the DXC-327B-series color camera. These phenomena do not mean that there is anything wrong with the camera.

### Vertical smear

Smear tends to happen when an extremely bright object such as an electric light, fluorescent lamp, sunlight, or strong reflection is being shot.

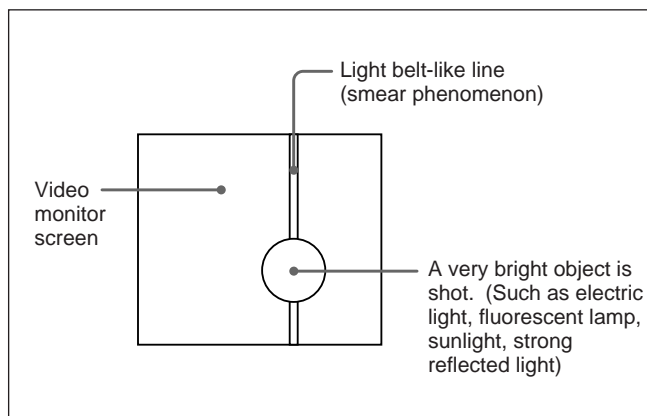

### White dots

White dots may appear in the video output if the camera is used at very high temperatures.

### Aliasing

Aliasing may occur when you shoot fine stripes or straight lines. The lines appear jagged.

### Poor pictures

You may not get a clear picture if the GAIN selector is set to 18 dB when you are using the electronic shutter. Use the electronics shutter under lighting conditions where you can obtain a clear picture with the GAIN selector set to the 0 or 9 dB position.

---

## Power HAD™ Sensor CCD Chip design

The Power HAD™ Sensor CCD Chip design employs three 1/2-inch CCD (Charge Coupled Device) images each having a total of about 380,000 (NTSC) or 440,000 (PAL) effective picture elements. The CCD offers better picture quality over tube type pick-up devices by providing;

- higher resolution and sensitivity
- lower lag, higher image burning resistance, and no deflection distortion
- less vibration and magnetic field distortion
- higher S/N ratio that allows you to raise the video output level by 9 dB or 18 dB to get a clear picture under low light conditions.

---

## Maximum system versatility

By attaching optional equipment you can expand the usability of the camera:

- the CA-537/537P Camera Adaptor enables you to control the camera via a camera control unit or VTR.
- the CA-325A/325AP or CA-325B enables multiple outputs of RGB format signal.
- a Hi8 format videocassette recorder or a Betacam format videocassette recorder PVV-3/3P, Pro 2000 series, turns your unit into a camcorder.
- the CCU-M5/M5P Camera Control Unit allow you to use the camera as a studio camera.
- the various kinds of power sources (battery, AC and DC) allow you to use the camera under many power situations.

---

## Electronic shutter

The built-in electronic shutter ensures better pictures of fast moving objects with little blurring.

---

## Automatic adjustment and memory functions

The camera automatically adjusts white/black balance as well as camera settings, and stores the adjustments for later use.

---

## Viewfinder displays

So you don't have to take your eye off what you are shooting, the viewfinder displays adjustment indications and warning. The viewfinder shows the following four displays;

**Characters:** Show switch settings, warning indications, and the title characters to be superimposed.

**Zebra pattern:** Appears on the portion of the screen where the video output level is about 70 to 80% IRE (for NTSC) or 490 to 560 mV (for PAL). This pattern acts as a reference when you manually adjust the iris.

**Safety zone marker and center marker:** Indicate the safety zone for shooting and the center of the picture.

**Status indicators:** The REC/TALLY indicator flashes to warn the connected VTR malfunctions, the BATT indicator the weak power of the installed battery pack, and the SHUTTER and GAIN UP indicators show the setting status of the corresponding switches.

# Location and Function of Parts

## DXC-327B/327BP Camera Head

The DXC-327B/327BP Camera Head is the modular core of this multipurpose camera system. Depending on your purpose, connect VTRs and camera control

units to it via the CA-537/537P or CA-327/327P Camera Adaptor.

### Camera head power supply and indications

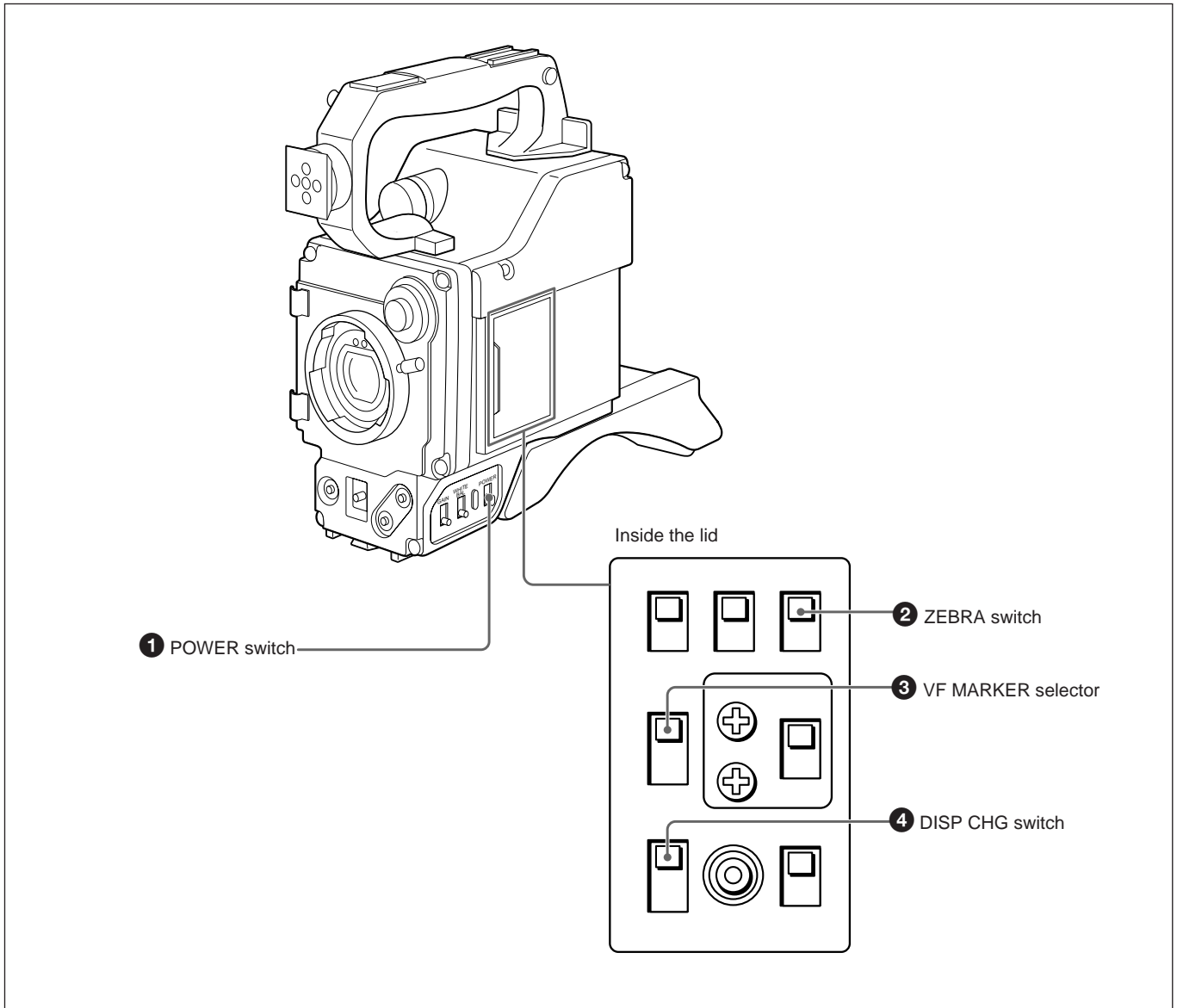

---

**① POWER switch**

**OFF:** Turns the camera off.

**ON SAVE:** Select to save power. When you press the VTR start button, there is a delay before recording starts, but the amount of power consumed in this mode is less than when the VTR is in stand-by mode (STBY).

This function is activated only when the VTR has the power saving function.

**ON STBY:** Select for a quick start. When you press the VTR start button, recording starts immediately. In this mode, power continues to be consumed while the drum heads rotate.

**② ZEBRA switch**

**ON:** Select to display the zebra pattern on the viewfinder screen for manual iris adjustment. The zebra pattern appears in the picture where the video level is about 70 to 80% IRE (for NTSC) or about 490 to 560 mV (for PAL). (See page 64.)

**OFF:** Select not to display the zebra pattern.

**③ VF MARKER (viewfinder safety zone marker and/or center marker) selector**

Use this selector to display the safety zone marker and/or center marker on the viewfinder screen.

**OFF:** Indicates neither of the markers.

**1:** Indicates the safety zone marker.

**2:** Indicates both of the markers.

**④ DISP CHG (display change) switch**

Push this switch to change the character display mode of the viewfinder screen. (See page 49.)

# Location and Function of Parts

## Camera head attachments and input/output connectors

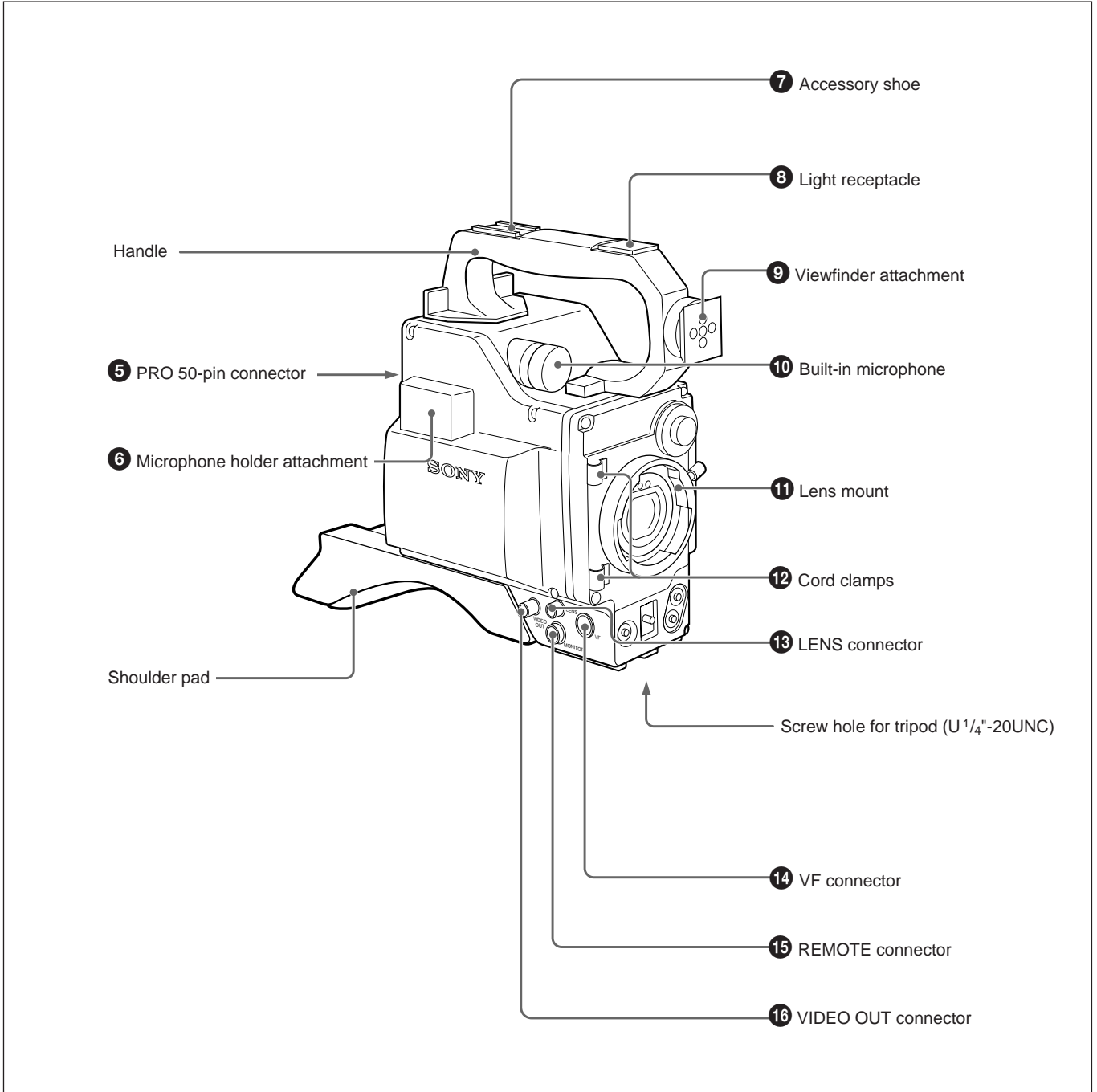

### **5 PRO 50-pin connector**

Connect to the 50-pin connector of the camera adaptor or EVV-9000/9000P, PVV-1/1P/1A/1AP/3/3P. (See pages 22 to 24.)

### **6 Microphone holder attachment**

Attach an optional CAC-12 microphone holder here. (See page 29.)

### **7 Accessory shoe**

Attach an optional accessory such as an DXF-40B/40BCE, DXF-50B/50BCE viewfinder here.

### **8 Light receptacle**

Attach an optional video light or other accessories here.

### **9 Viewfinder attachment**

Attach the DXF-601/601CE viewfinder here.

### **10 Built-in microphone**

The built-in microphone allows you to make a sound recording along with the video recording.

When an external microphone is connected to the MIC IN connector on the CA-537/537P Camera Adaptor, the built-in microphone does not function. We recommend you use a uni-directional external microphone to get a better sound recording when a VTR such as a PVV-1/1P/1A/1AP/3/3P, EVV-9000/9000P, is directly attached to this unit.

### **11 Lens mount**

Attach the VCL-714BX Zoom Lens or another 1/2" lens and related equipment here.

### **12 Cord clamps**

Secure the viewfinder cord.

### **13 LENS connector (6-pin)**

Connect the lens cord when a 2/3-inch lens is attached to the camera head using an LO-32BMT Lens Mount Adaptor or when an MVA-40 Microscope Adaptor is attached to the camera.

### **14 VF connector (8-pin)**

Connect the viewfinder cord here.

### **15 REMOTE connector (10-pin)**

To operate this camera from an RM-M7G Camera Remote Control Unit, connect the camera to the remote control unit via this connector. Make sure the CAMERA SELECT switch on the bottom of the RM-M7G is set to "1", the factory preset position.

### **16 VIDEO OUT (output) connector (BNC type)**

To check the picture of the camera you are shooting, connect to the input connector of a video monitor. Also you can connect to the video input of a VTR. Title characters display on the viewfinder screen output from this connector.

# Location and Function of Parts

## Camera head switches and controls

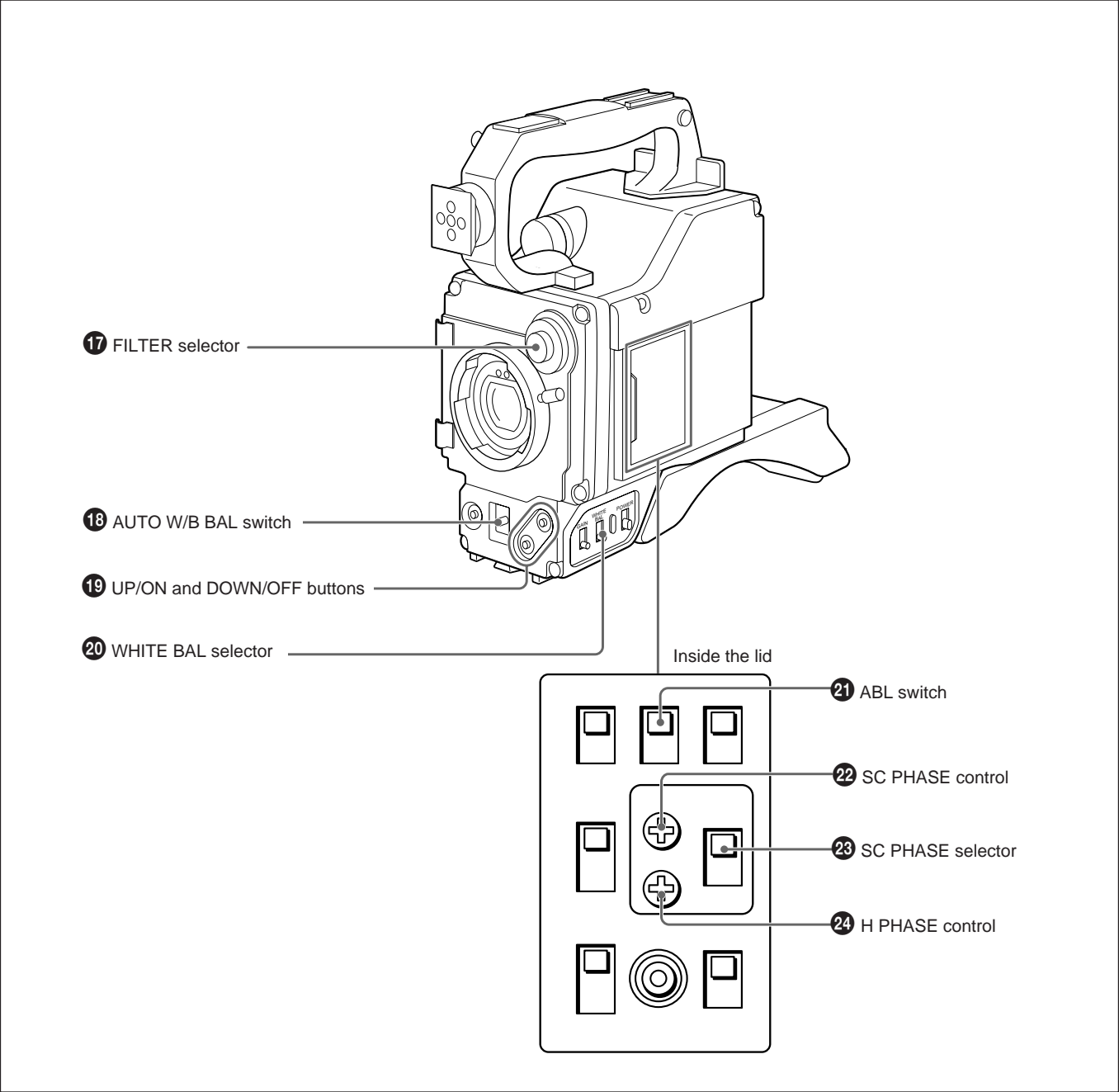

## 17 FILTER selector

Selects the appropriate filter according to lighting conditions.

Filter number	Color temperature	Lighting conditions
1	3200K	Iodine lamp, sunrise or sunset
2	5600K+ <sup>1/16</sup> ND <sup>1)</sup>	Bright outdoor
3	5600K	Cloudy or rainy

<sup>1)</sup> ND: Neutral density filter

## 18 AUTO W/B BAL (automatic white/black balance adjustment) switch

Select "A" or "B" with the WHITE BAL selector and push this switch to WHT to automatically adjust white balance. To automatically adjust black balance, push this switch to BLK. You can do this irrespective of the WHITE BAL selector setting. The setting value is stored in the camera's memory. When you release this switch, the switch returns to the center position automatically.

## 19 UP/ON and DOWN/OFF buttons

Press either of these buttons with the DISP CHG switch to make one of the following six settings to:

- Set the title characters (see page 67.)
- Turn on/off the LOW LIGHT indication (see page 47.)
- Adjust the reference level of the automatic iris (see page 53.)
- Adjust the detail level (see page 63.)
- Adjust the master pedestal level (see page 58.)
- Adjust the shutter speed (see page 59.)

## 20 WHITE BAL (white balance memory) selector

**A or B:** Select A or B to make the camera use the white balance setting stored in memory position A or B.

**PRE:** Set to PRE when there is no time to adjust the white balance. This function provides a factory-preset white balance value for a color temperature of 3200K for the selected FILTER selector position.

## 21 ABL (automatic black level) switch

When the entire picture is too bright, such as during outdoor shooting, set this switch to ON. A well-contrasted picture will be obtained.

## 22 SC (subcarrier) PHASE control

Turn this control to fine tune the SC phase using a small screwdriver. Do this after roughly adjusting the SC phase using the SC PHASE selector (see page 66.) Do this adjustment when you are using two or more cameras simultaneously.

## 23 SC (subcarrier) PHASE selector

Switch this selector to 0° or 180° to roughly adjust the SC phase difference between the gen-lock input and the video output signals when using two or more cameras simultaneously. (See page 66.)

## 24 H (horizontal) PHASE control

Turn this control to adjust the H phase difference between the gen-lock input and video output signals using a small screwdriver. (See page 66.)

# Location and Function of Parts

## Camera head output selectors

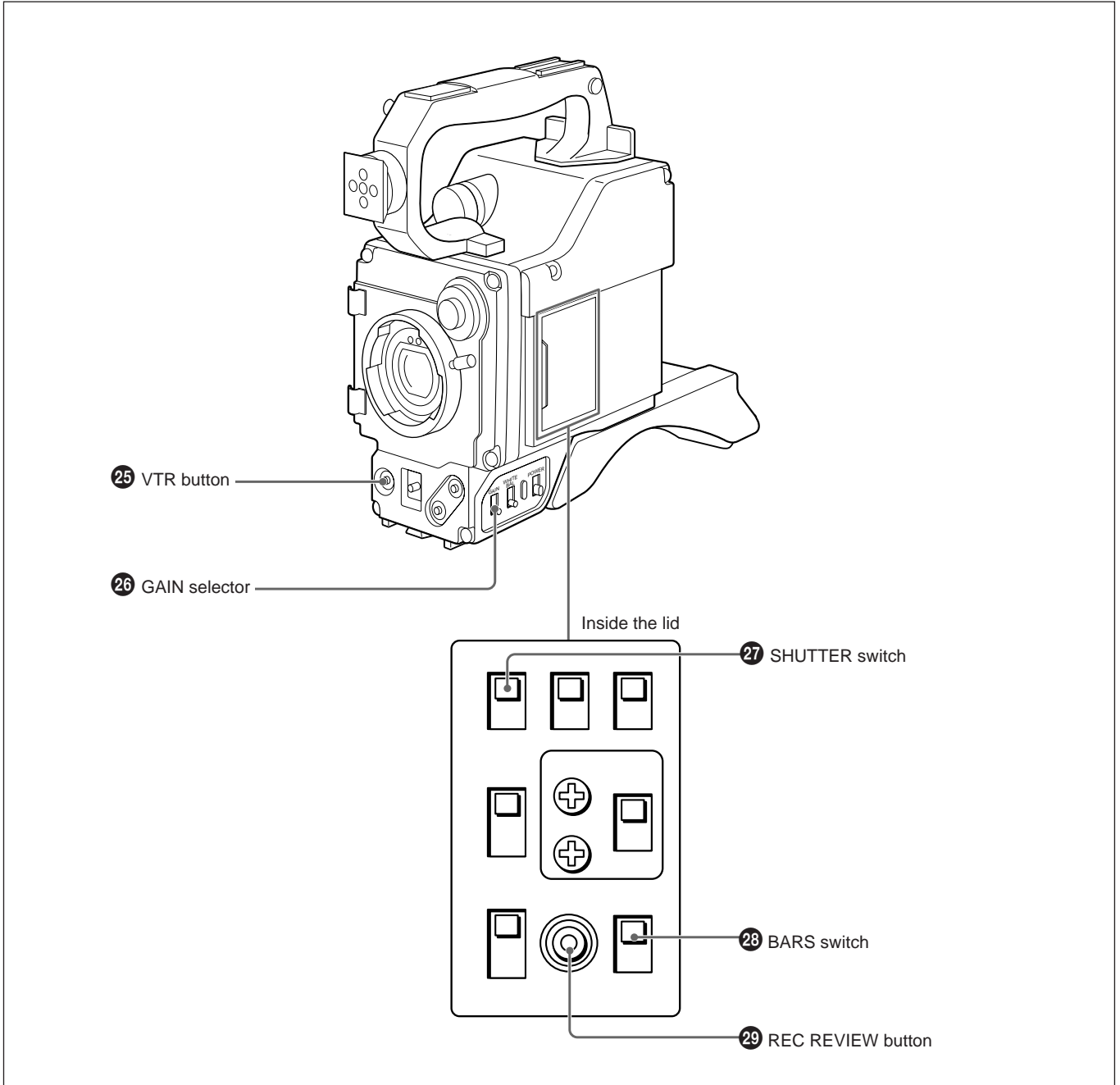

---

**25 VTR button**

When connecting the camera to a portable VTR, press this button to start and stop recording.

When connecting the camera to a CCU-M7/M7P or CCU-M5/M5P, keep this button depressed to monitor the return video pictures on the viewfinder. Release it to monitor the camera pictures.

**26 GAIN selector**

Select a higher setting to lighten dark pictures.

**27 SHUTTER switch**

Flip this switch to control the electronic shutter.

**ON:** Flip to this position to activate the electronic shutter. To select the shutter speed, use the UP/ON or DOWN/OFF button. (See page 59.)

**OFF:** Flip to this position to deactivate the electronic shutter.

**28 BARS (color bar generation) switch**

**ON:** Set to this position to display the color bars on the viewfinder or video monitor screen when adjusting its contrast and brightness. The color bars are output to the viewfinder, video monitor or other connected equipment from the following connectors.

- VIDEO OUT connector
- VF connector
- REMOTE connector
- VTR/CCU/CMA connector (on the camera adaptor)

**OFF:** Set to this position for normal operation.

**29 REC (record) REVIEW button**

Press this button when using a VTR such as an EVV-9000/9000P, PVV-1/1P/1A/1AP/3/3P, with this camera to check the recorded picture while recording. (For details, refer to the operations manual for the cassette recorder.)

## Location and Function of Parts

### CA-537/537P Camera Adaptor (optional)

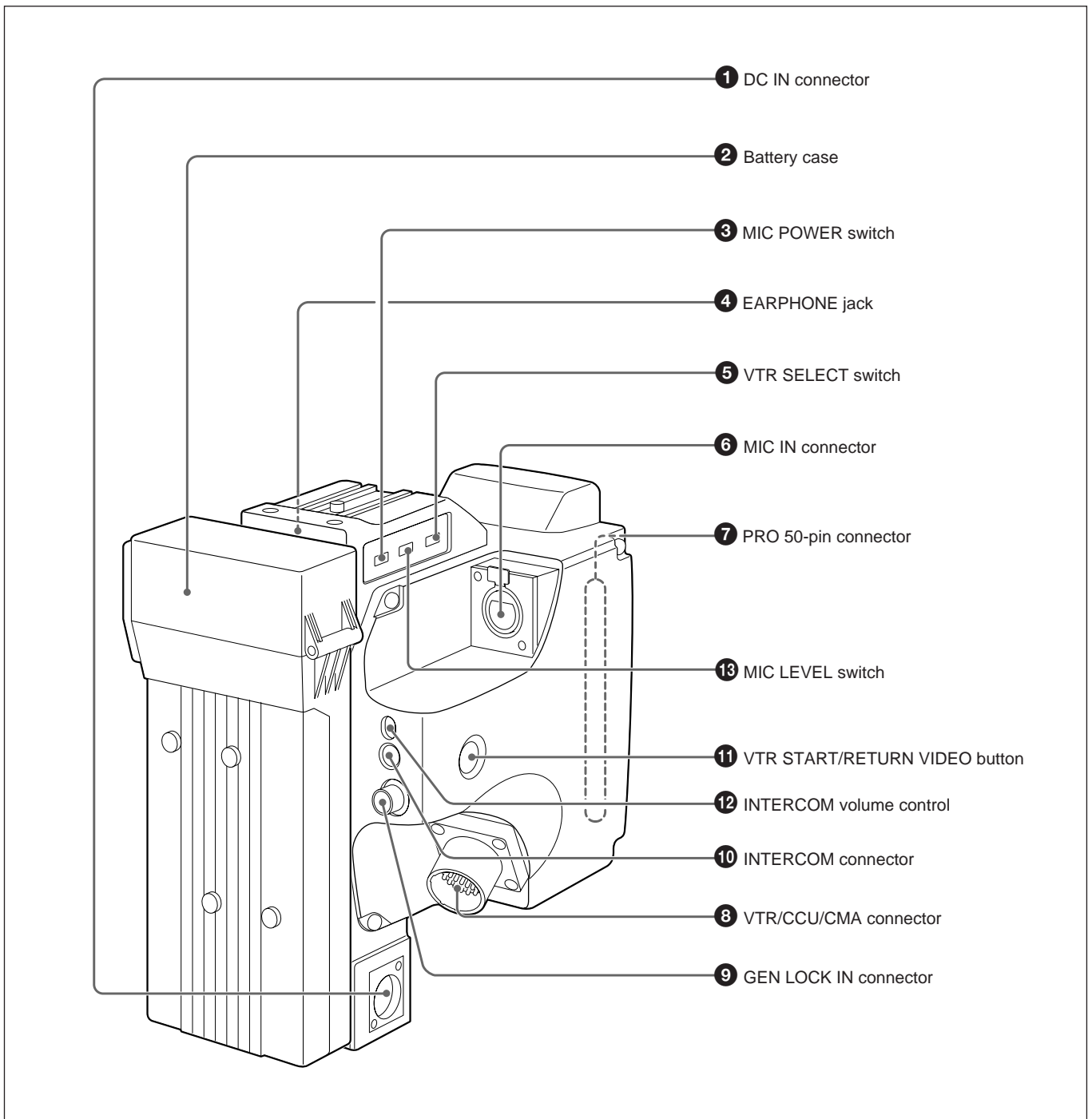

---

## Power supply

### ① DC IN (input) connector (XLR-4 pin)

Connect an external DC power source (12 volt DC) here to supply power to the camera adaptor and camera.

When the power is supplied from this connector, power supplied from a battery pack or from the VTR/CCU/CMA connector is not used.

### ② Battery case

Insert an NP-1B battery pack (not supplied) here.

### ③ MIC (microphone) POWER switch

**ON:** When you use the microphone of a phantom powering system, set the switch to this position. The power is supplied to the microphone from the MIC IN connector.

**OFF:** When you use a microphone other than a phantom powering system, set the switch to the OFF position.

---

## Input and output connectors

### ④ EARPHONE jack (minijack)

Connect an earphone here to monitor the playback or recording sound from the VTR.

#### Note

Some type of VTR may not let you monitor the sound output from the VTR. (See page 45).

### ⑤ VTR SELECT switch

Use this switch according to the type of VTR connected to the camera. (See page 37).

#### Caution

Be sure to set the VTR SELECT switch to the correct VTR type; otherwise, the VTR will not operate properly.

### ⑥ MIC IN (microphone input) connector (XLR 3-pin)

Connect an external microphone here.

### ⑦ PRO 50-pin connector

Connect to the 50-pin connector on the camera head.

### ⑧ VTR/CCU/CMA connector (26-pin)

Connect a VTR, CCU-M7/M7P or CCU-M5/M5P Camera Control Unit or CMA-8A/8ACE Camera Adaptor here.

### ⑨ GEN LOCK IN (gen-lock input) connector (BNC-type)

Connect the gen-lock sync signal (VBS or BS) for synchronization here.

### ⑩ INTERCOM connector

Connect a DR-100A intercom headset here. The DR-100A enables communication between the camera and the connected CCU-M7/M7P or CCU-M5/M5P Camera Control Unit or video switcher.

---

## Switches and controls

### ⑪ VTR START/RETURN VIDEO button

**When a portable VTR is connected to the VTR/CCU/CMA connector:** Press this button to start and stop recording.

**When the CCU-M7/M7P or CCU-M5/M5P Camera Control Unit is connected:** Keep this button depressed to monitor the return video picture, and release it to monitor the camera picture.

### ⑫ INTERCOM volume control

Controls the volume level through the DR-100A Intercom Headset.

### ⑬ MIC (microphone) LEVEL switch

Set this switch according to the sensitivity of the MIC IN on the VTR and CCU. If the sensitivity is high, set it to a minimum of -20 dB; if it is low, set it to a maximum of -60 dB. (Refer to the operations manual of the VTR.)

# Location and Function of Parts

## VCL-714BX Zoom Lens

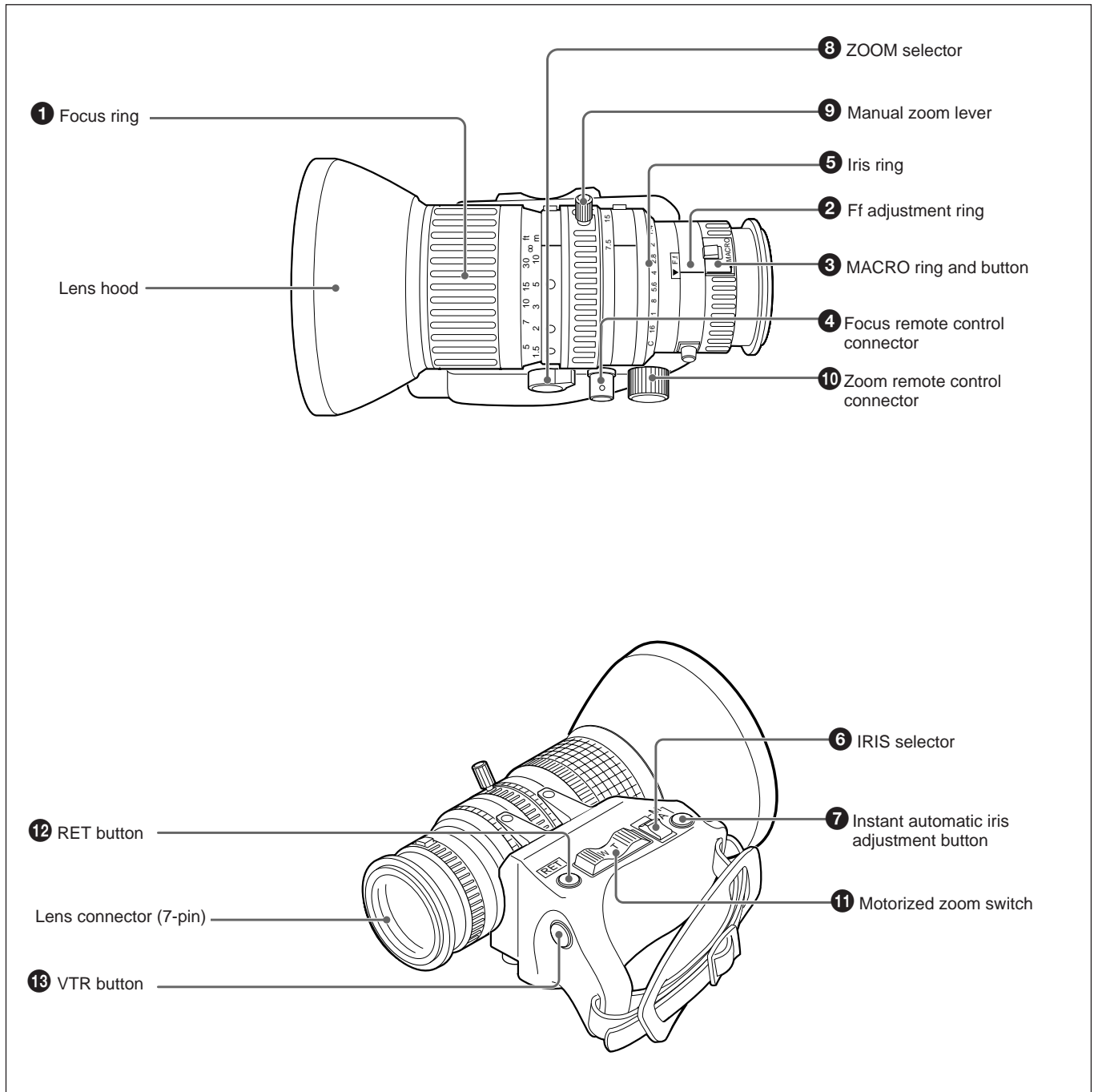

---

## Focusing

### ① Focus ring

To focus, turn this ring.

### ② Ff (flange focal length) adjustment ring

To adjust the Ff, release the screw and turn the ring.

### ③ MACRO (close-up) ring and button

To do close-up, turn the MACRO ring while sliding the button.

### ④ Focus remote control connector (3-pin)

Not used.

---

## Iris adjustment

### ⑤ Iris ring

To manually adjust the iris, turn this ring with the iris selector set to M.

### ⑥ IRIS selector

**A (automatic):** Select to adjust the iris automatically.

**M (manual):** Select to adjust the iris manually.

### ⑦ Instant automatic iris adjustment button

To automatically adjust the iris during manual iris adjustment, keep this button depressed. When the button is released, the iris will remain at the value that has just been obtained and will stay that way until you manually adjust the iris again.

---

## Zoom controls

### ⑧ ZOOM selector

**S (servo):** Select for motorized zoom action.

**M (manual):** Select for manual zoom.

### ⑨ Manual zoom lever

To do manual zoom, move this lever with the ZOOM selector set to M.

### ⑩ Zoom remote control connector (8-pin)

To do remote control zoom when the camera is attached to a tripod, connect an LO-23 Lens Remote Control Unit (optional) here.

### ⑪ Motorized zoom switch

For motorized zoom action, set the zoom selector to S. Then, press either end of the motorized zoom switch, W for a wide angle shot, and T for a telephoto shot. Press the switch down all the way for faster zoom action and only slightly for slow zoom action.

---

## Recording controls

### ⑫ RET (return video) button

**When a portable VTR is connected,** keep this button depressed to monitor the E-E picture on the viewfinder screen. Release the button to monitor the camera picture.

**When a CCU-M7/M7P or CCU-M5/M5P Camera Control Unit is connected,** keep this button depressed to monitor the return video picture on the viewfinder screen. Release the button to monitor the camera picture.

### ⑬ VTR button

**When a portable VTR is connected,** press this button to stop and start recording. This button has the same function as the VTR button on the camera head.

**When a CCU-M7/M7P or CCU-M5/M5P Camera Control Unit is connected,** keep this button depressed to monitor the return video picture on the viewfinder screen. Release the button to monitor the camera picture. Starting and stopping recording is controlled on the VTR.

# Location and Function of Parts

## DXF-601/601CE Electronic Viewfinder

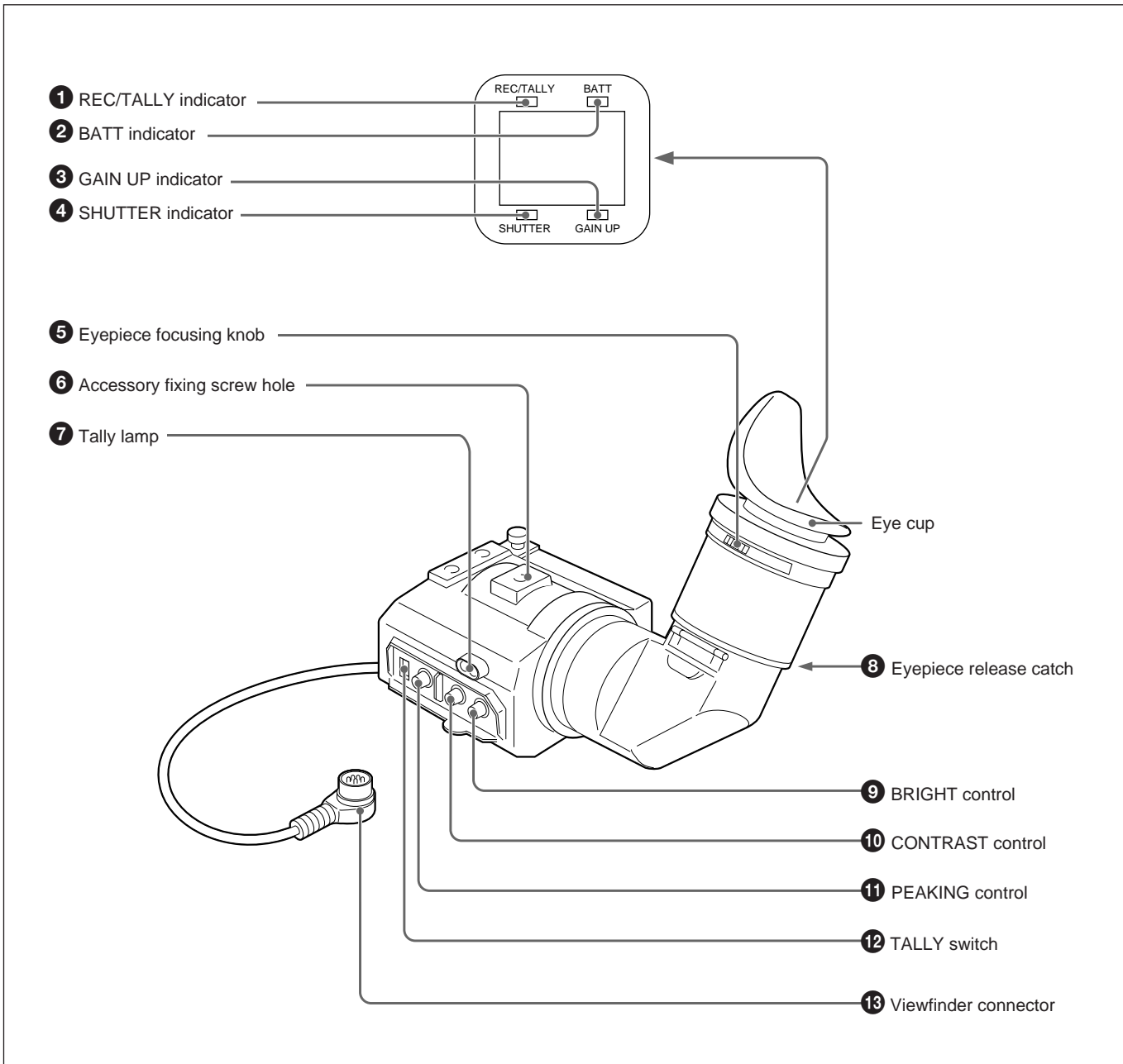

**① REC/TALLY (recording/tally) indicator (red)**

- From the time when you press the VTR button on the lens or camera head, this flashes until recording starts, then stays on continuously during recording.
- When using a camera control unit, this lights when this camera is selected.
- This is also used to indicate a fault.

**② BATT (battery) indicator (red)**

This indicates when the battery capacity is low. (See page 41.)

**Note**

When using a camera control unit, this indicator flashes when you operate the controls, but this is not a malfunction.

**③ GAIN UP indicator (orange)**

This lights when the gain is 3 dB or more.

**④ SHUTTER indicator (red)**

This lights when the SHUTTER switch is in the ON position.

**⑤ Eyepiece focusing knob**

Turn this to adjust the viewfinder focus to match your eyesight. (See page 50.)

**⑥ Accessory fixing screw hole**

Attach optional video lights or other accessories here.

**⑦ Tally lamp**

When the TALLY switch is in the ON position, this operates in the same way as the REC/TALLY indicator.

**⑧ Eyepiece release catch**

To view the viewfinder screen directly, press this catch, and hinge up the eyepiece.

**⑨ BRIGHT (brightness) control**

This adjusts the brightness of the viewfinder image. (See page 50.)

**⑩ CONTRAST control**

This adjusts the contrast of the viewfinder image. (See page 50.)

**⑪ PEAKING control**

This adjusts the outline intensity of the viewfinder image. (See page 50.)

**⑫ TALLY switch**

Set this switch to ON position to use the tally lamp.

**⑬ Viewfinder connector**

Connect this to the VF connector on the camera head.

**Note on using a supplied viewfinder**

Do not leave the viewfinder so that sunlight can enter the eyepiece lens. It is possible for sunlight focused by the eyepiece to cause very high temperatures, and melt the inside of the viewfinder

# Accessory Attachment

## Attaching/Detaching a Camera Adaptor

To use the DXC-327B/327BP camera head as a stand-alone camera, set up the camera head with a camera control unit or portable VTR using as interface the optional Sony CA-537/537P or CA-327/327P Camera

Adaptor. Refer to the CA-327/327P operations manual for instructions on how to attach and detach that unit. Refer to the below procedure to attach the CA-537/537P Camera Adaptor.

### Attaching the CA-537/537P camera adaptor

- 1 Place the camera adaptor on the camera head aligning the guide with the guide hole.

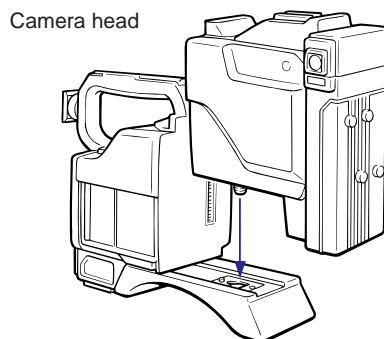

- 2 Push the camera adaptor forward along the grooves until its 50-pin connector locks into the PRO 50-pin connector on the camera.

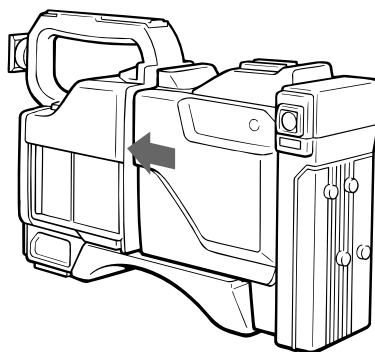

- 3 Fix the camera adaptor to the camera head using the two screws.

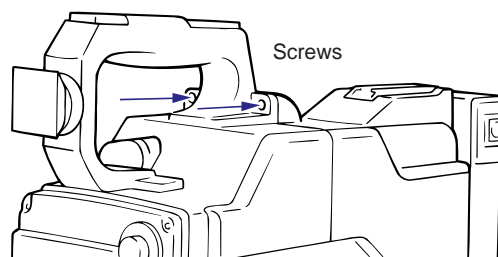

- 
- 4** Tighten the two screws at the bottom of the shoulder pad.

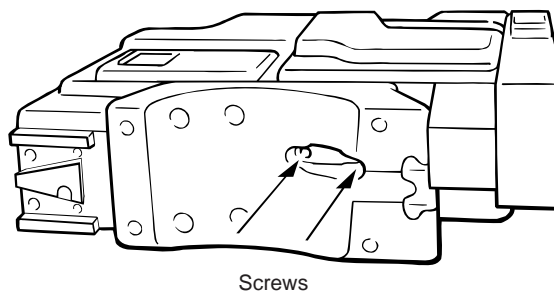

---

### Detaching the camera adaptor

To detach the camera adaptor, reverse the order of the above procedure.

**Note on connection with the CA-327/327P camera adaptor**

You can connect the following CA-327/327P series camera adaptors to the DXC-327B/327BP:

CA-327: Serial No. 10271 and higher for the DXC-327B.

CA-327P: Serial No. 40101 and higher for the DXC-327BP.

# Accessory Attachment

## Attaching a Videocassette Recorder

To attach an EVV-9000/9000P Hi8 Format Videocassette Recorder to the camera head, follow the procedures for attaching and detaching the CA-537/537P Camera Adaptor.

To attach a Betacam format video cassette recorder such as a PVV-1/1P/1A/1AP/3/3P, follow the procedure below. Refer to the EVV-9000/9000P and PVV-1/1P/1A/1AP/3/3P operations manual for details.

- 1** Remove the screw of the accessory shoe on the camera head using a flat-head screwdriver, and remove the plate spring.
- 2** Attach the PVV-1/1P/1A/1AP/3/3P following the procedures for attaching the CA-537/537P.

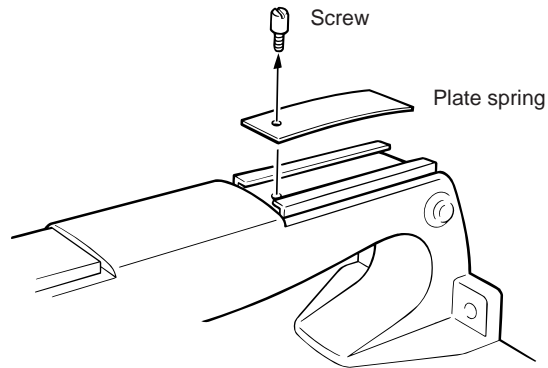

## Attaching the Zoom Lens and Optional Filter

Check that the zoom lens you are going to mount is a  $\frac{1}{2}$ -inch lens.

### Caution

A  $\frac{2}{3}$ -inch lens cannot be directly attached to the lens mount of the video camera. Do not try to mount a  $\frac{2}{3}$ -inch lens directly to the video camera's lens mount as doing so will damage the optical block of the camera. To mount a  $\frac{2}{3}$ -inch lens, use an LO-32BMT Lens Mount Adaptor (optional).

### Preparations

Remove the protective caps from the mounts of the camera and the lens.

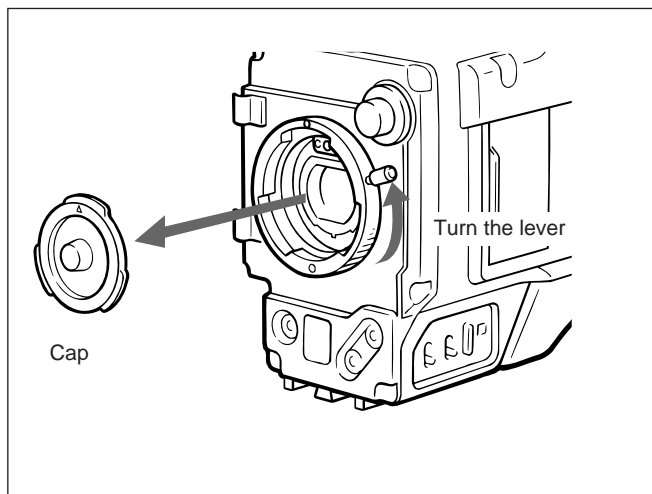

# Accessory Attachment

## Attaching the zoom lens

- 1 Turn the mount clamp lever fully counter clockwise to align the lens notch and the red point.

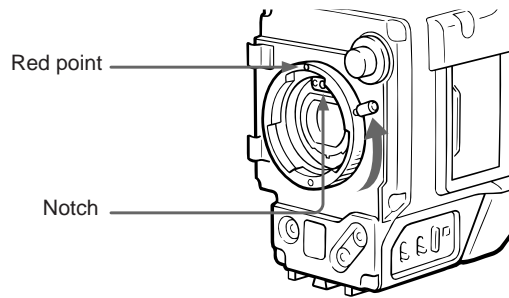

- 2 Align the center pin in the lens with the notch in the lens mount, and insert the lens into the mount.

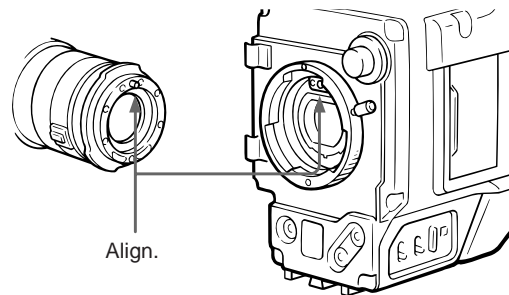

- 3 Holding the lens, push down on the lens fixing lever to tighten the ring and secure the lens.

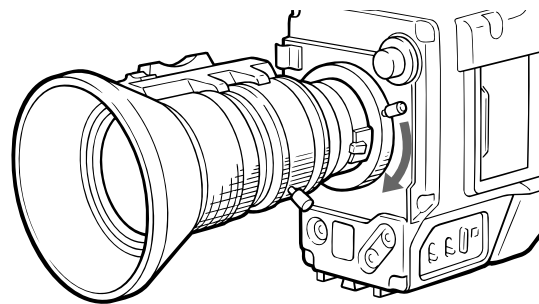

## Attaching an optional filter

Screw the filter on clockwise to attach.

### When a VCL-714BX Zoom Lens is used

Use a filter whose diameter is 72 mm and pitch is 0.75 mm.

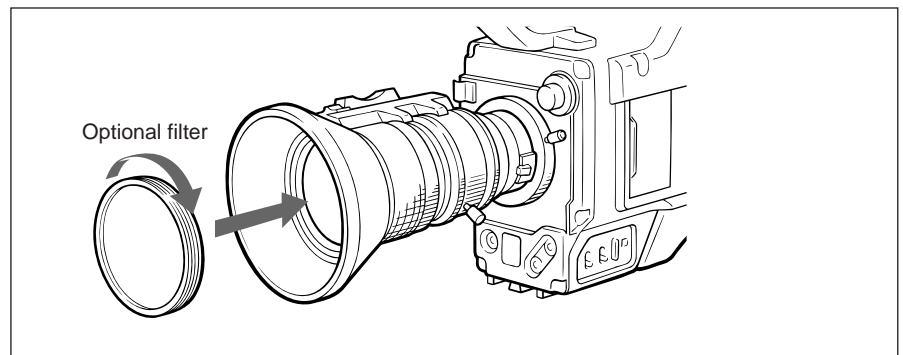

## Attaching and Adjusting the Electronic Viewfinder

- 1 Loosen the lock ring. Align and guide the viewfinder along the mount.

**To detach the viewfinder,** loosen the lock ring. Then while pulling up the pin, slide the viewfinder off the mount.

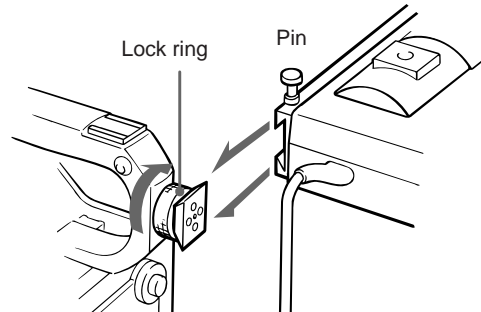

- 2 Turn and tighten the lock ring to fix the viewfinder.

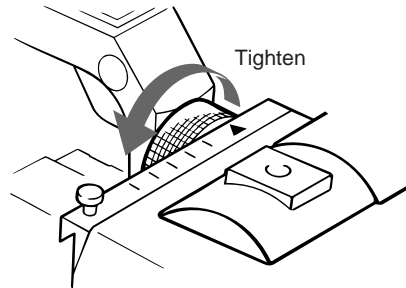

- 3 Connect the viewfinder connector cable to the VF connector on the camera head.

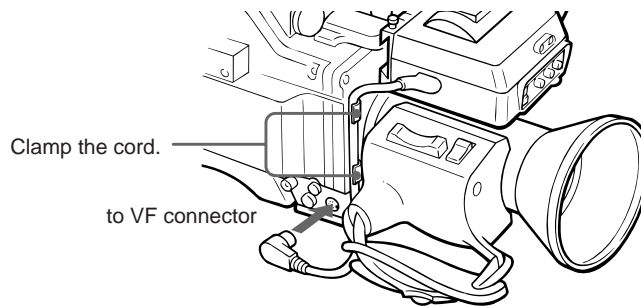

## Accessory Attachment

### Adjusting to the left or right

- 1 Loosen the lock ring.
- 2 Looking through the eyepiece, slide the viewfinder sideways to the most convenient position.
- 3 Tighten the lock ring when the viewfinder is in a comfortable position.

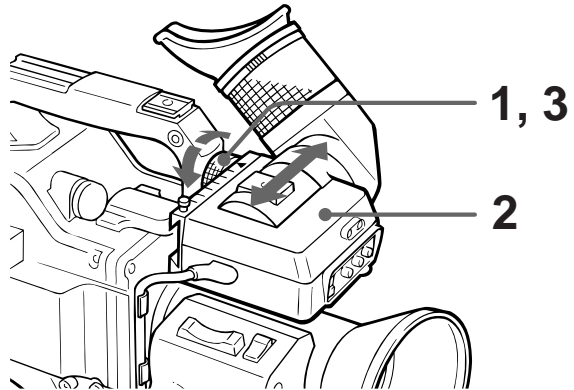

### Adjusting the angle

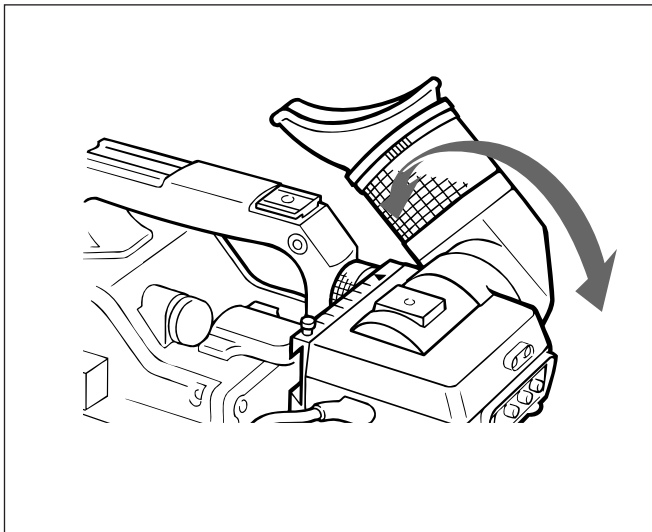

### Storing the unit in the carrying case

Always store the unit with the eye cup positioned downward, the viewfinder positioned as close to the camera body as possible, and the lock ring fastened.

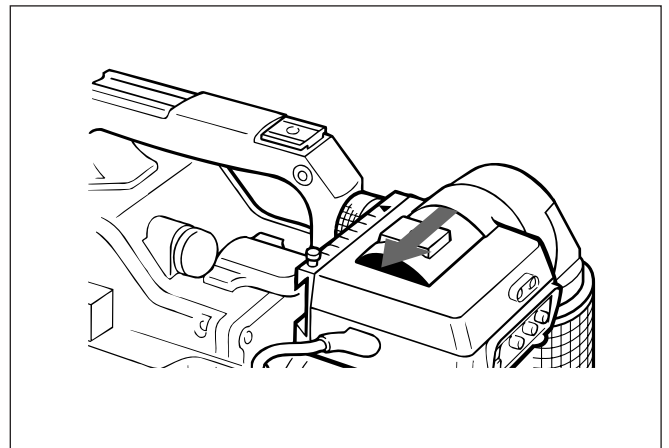

## Attaching a Microphone

In order to attach an ECM-670/672 External Microphone (optional), first fit a CAC-12 Microphone Holder (optional) to the camera head.

### Note

The ECM-670 should be used with a VTR or adaptor which has the phantom-powering function.

- 1 Remove the two screws from the side of the camera head.

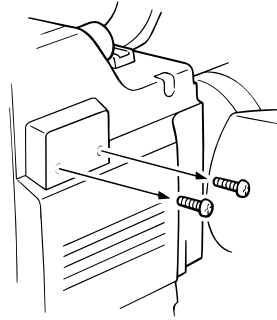

- 2 Using the screw removed in Step 1, attach the CAC-12 Microphone Holder.

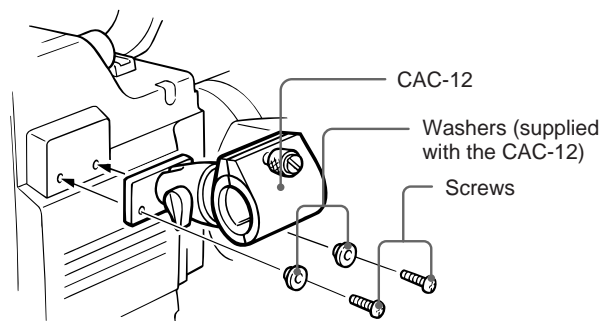

- 3 Loosen the microphone holder bolt.

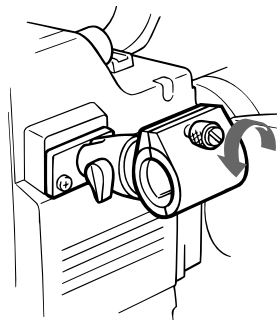

- 4 Open the microphone holder.

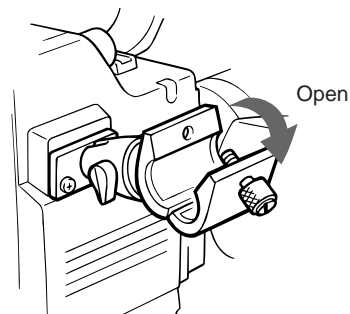

## Accessory Attachment

---

- 5** Insert the microphone in the microphone holder, close the holder and tighten the microphone holder bolt.

**When using a bayonet (thin) type microphone,** attach a microphone adaptor to the microphone.

**When the ECM-670 is used,** attach an adaptor supplied with the ECM-670.

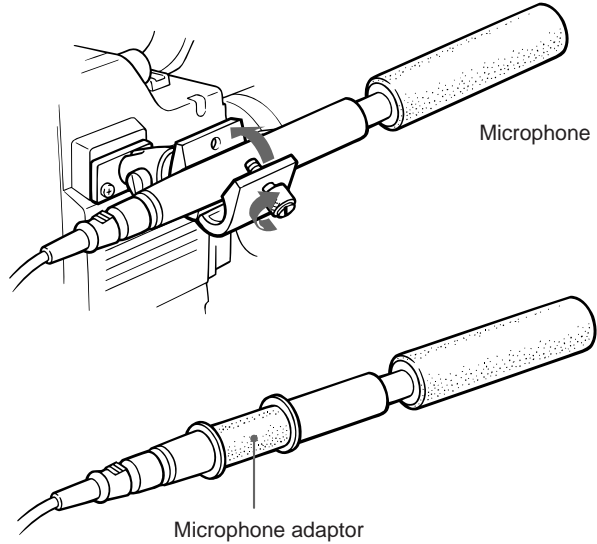

- 6** Connect the microphone cable to the MIC IN connector.

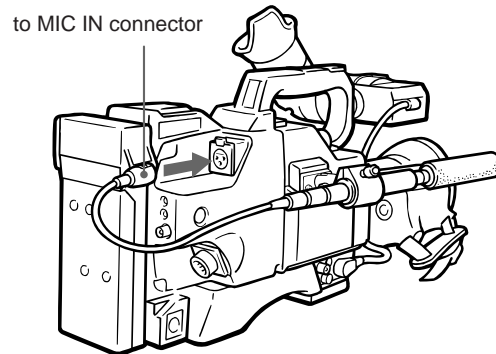

## Attaching/Detaching a Tripod

### Attaching the camera to the tripod

First attach the VCT-U14 Tripod Adaptor to the tripod, then mount the camera on the tripod adaptor.

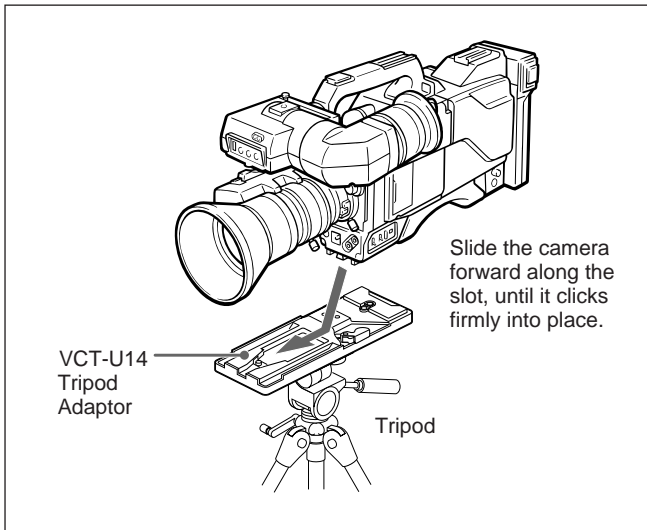

### Detaching the camera from the tripod

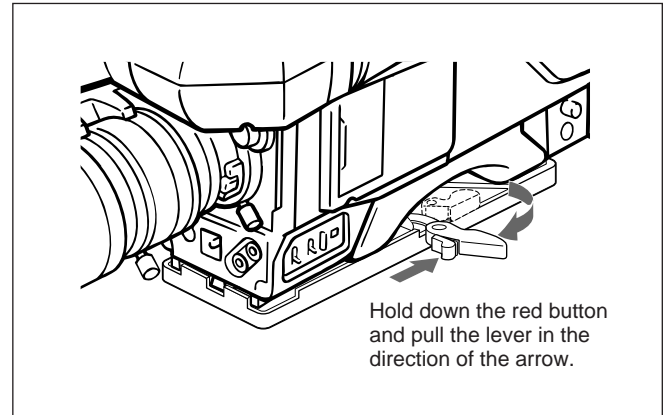

#### Note

After removing the camera, if the tripod adaptor pin has not returned to its original position, hold down the red button and move the lever in the direction of the arrow to return the pin to its original position. It is not possible to mount a camera with the pin left out.

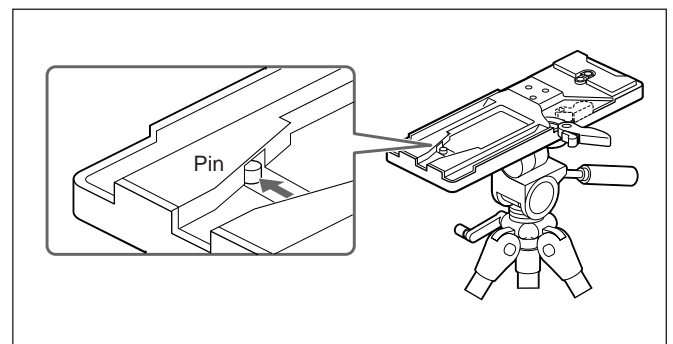

# Connections

Make sure the power switches on the camera, VTR, and other equipment are set to OFF.  
Attach the CA-537/537P Camera Adaptor to the camera head before attaching any of the below equipment.

Consult the “Differences in functions” on page 38 for details on the functions available with different VTRs.  
For the general use of the camera with a VTR attached, see “Basic Operations” on page 43.

## Connecting an S-VHS Format Portable VTR

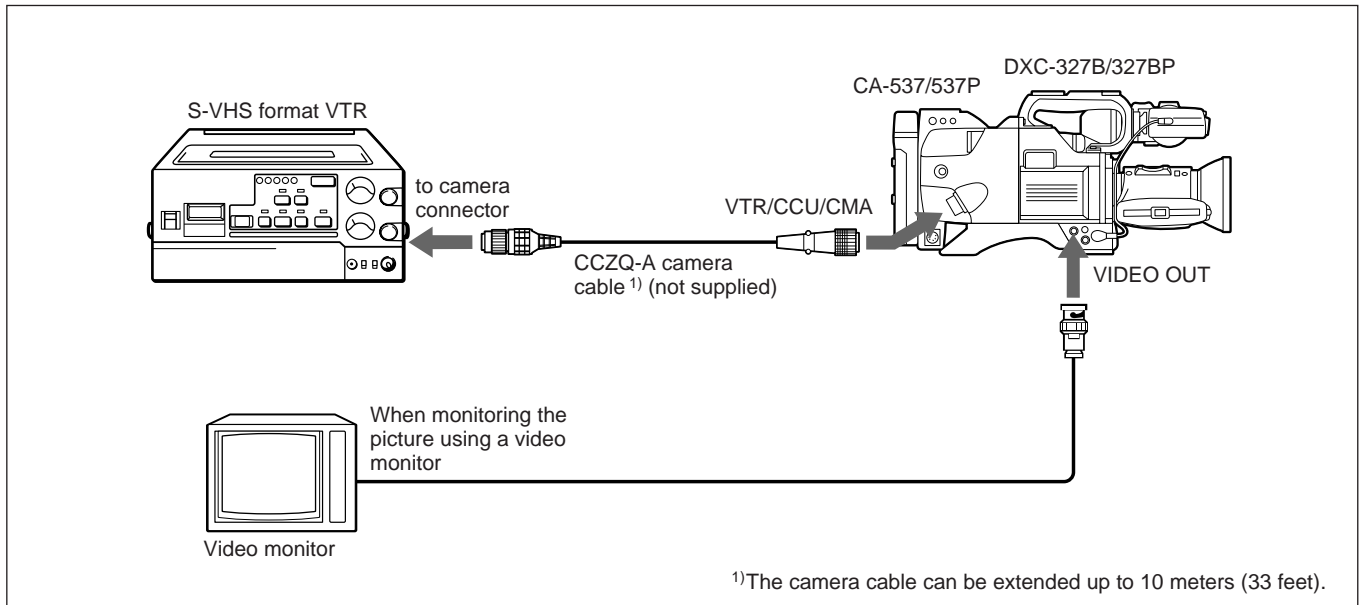

- When a video monitor equipped with an S-video input connector, connect the S-video connectors on the VTR and video monitor. Then a picture with high resolution with a Y/C separate signal can be monitored.
- When an S-VHS format VTR is connected via a CA-537/537P Camera Adaptor, set the VTR SELECT switch on the CA-537/537P to “3”. Then a Y/C separate signal is output from the VTR/CCU/CMA connector on the CA-537/537P.
- A composite video signal is output from the VIDEO OUT connector.

## Connecting a Portable VTR

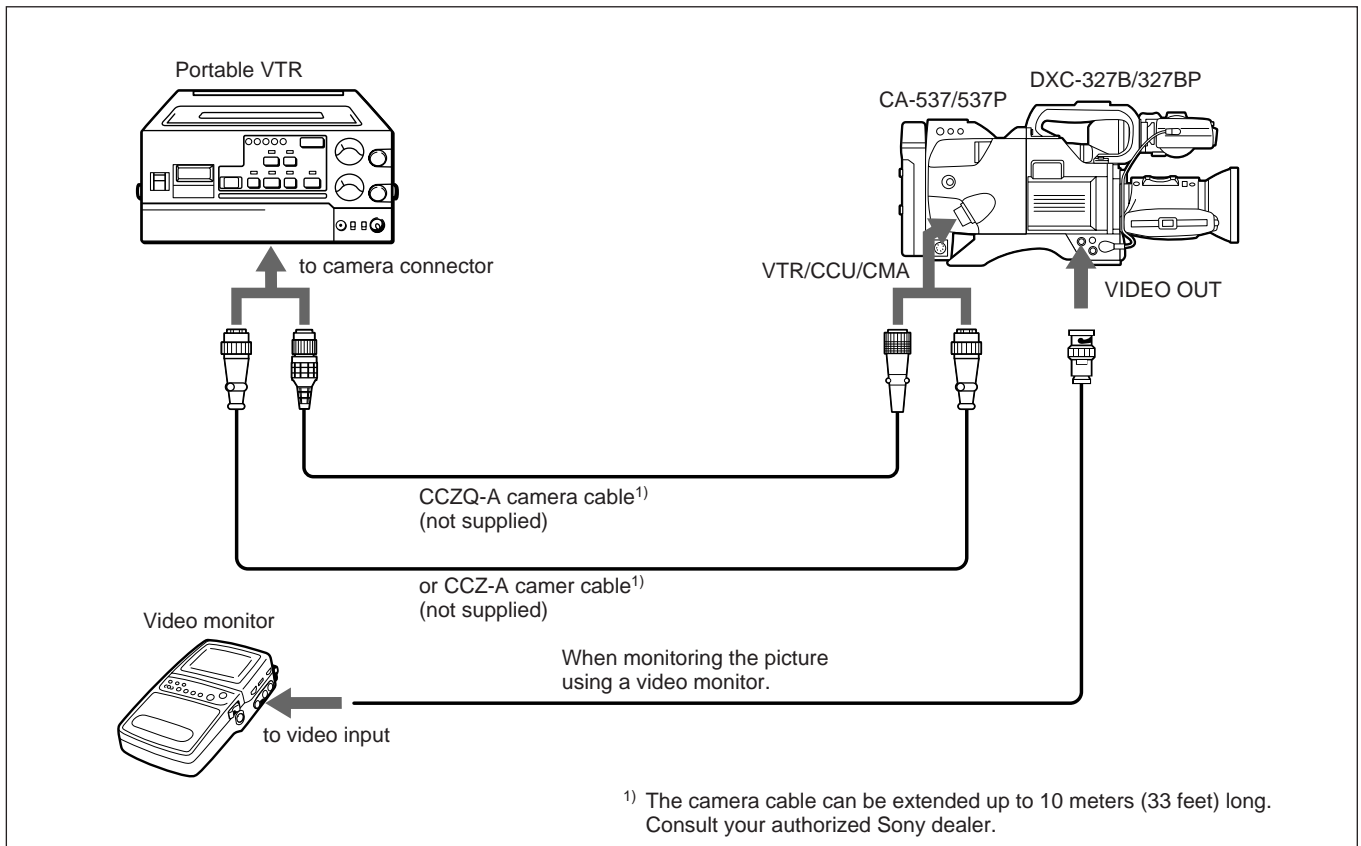

## Connecting an External Microphone

To avoid recording noise made while handling the camera, connect an external microphone to the MIC IN connector on the camera adaptor (see figure below).

With the below connections, note that the built-in microphone automatically shuts off.

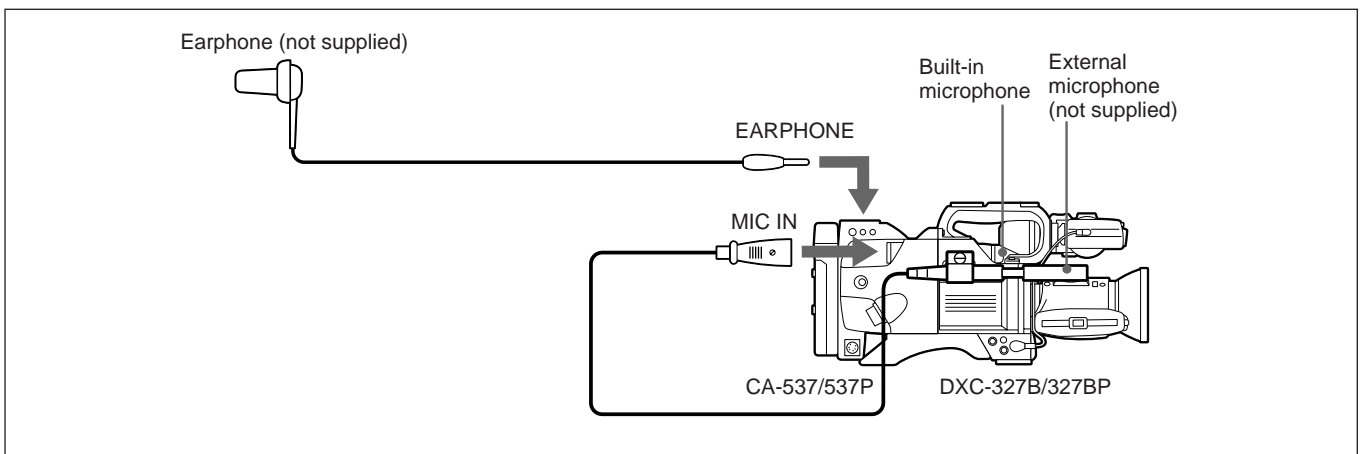

# Connections

## Connecting a Table-Top VTR

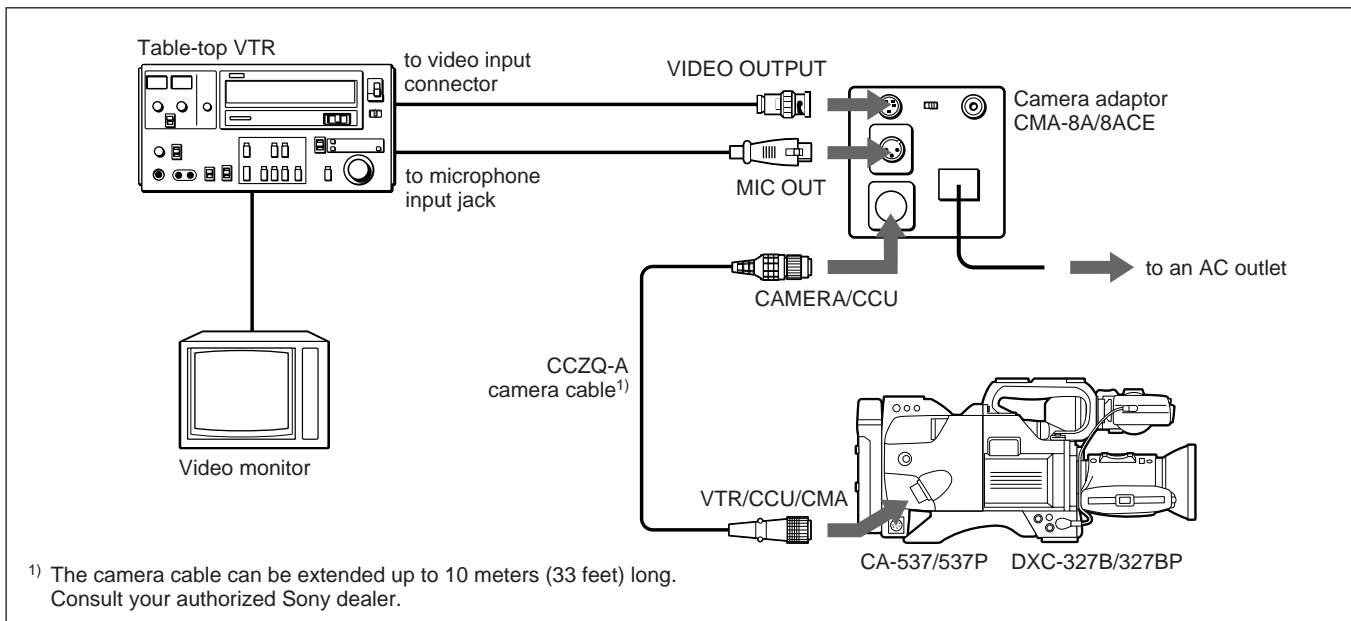

## Connecting a Camera Control Unit

### Connecting the CCU-M5/M5P/M7/M7P camera control unit

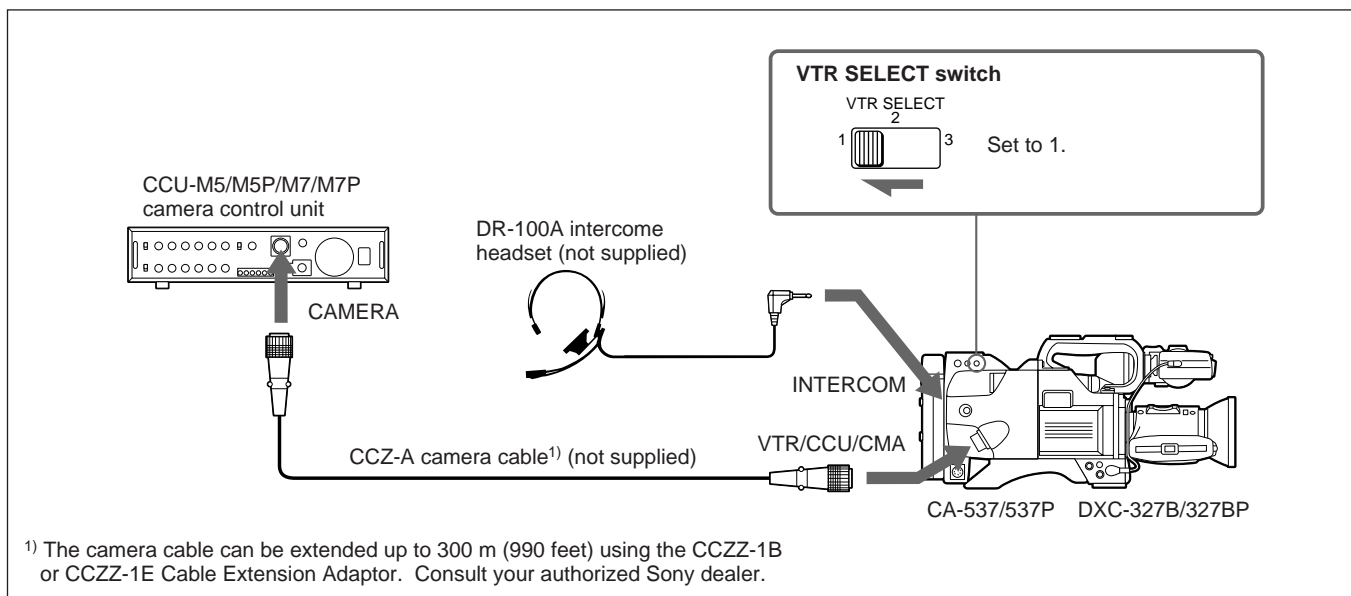

### Gamma and knee controls with the CCU-M7/M7P connected

When the camera is connected to the CCU-M7/M7P, the GAMMA controls and KNEE controls of the

CCU-M7/M7P do not affect the video output signal of the camera. However, the setting value of the GAMMA and KNEE level on the monitor screen change.

---

## Notes on use with the CCU-M7/M7P or CCU-M5/M5P camera control unit

### Switch setting

- Set the VTR SELECT switch on the camera adaptor to "1."
- When the camera is connected to the CCU, the following switches on the camera head do not operate:
  - GAIN selector
  - WHITE BAL selector
  - H PHASE control
  - SC PHASE control
  - SC PHASE selector
  - SHUTTER switch
  - BARS switch
  - ABL switch

### White/black balance adjustment

- When the W/B BALANCE selector on the CCU is set to PRESET or MANUAL, the CCU adjusts the white balance and takes priority over the setting done on the camera.
- If the W/B BALANCE selector is set to AUTO, the white balance can be adjusted using either the camera or CCU controls.
- Do automatic black balance adjustments by setting the W/B BALANCE selector on the CCU to AUTO or PRESET, and the AUTO W/B BAL switch on the camera to BLK.

## Connections

### Connecting a Remote Control Unit

By connecting an RM-M7G Remote Control Unit (optional), you can control the principal camera functions at a distance. For more details on using the remote control, consult your Sony dealer.

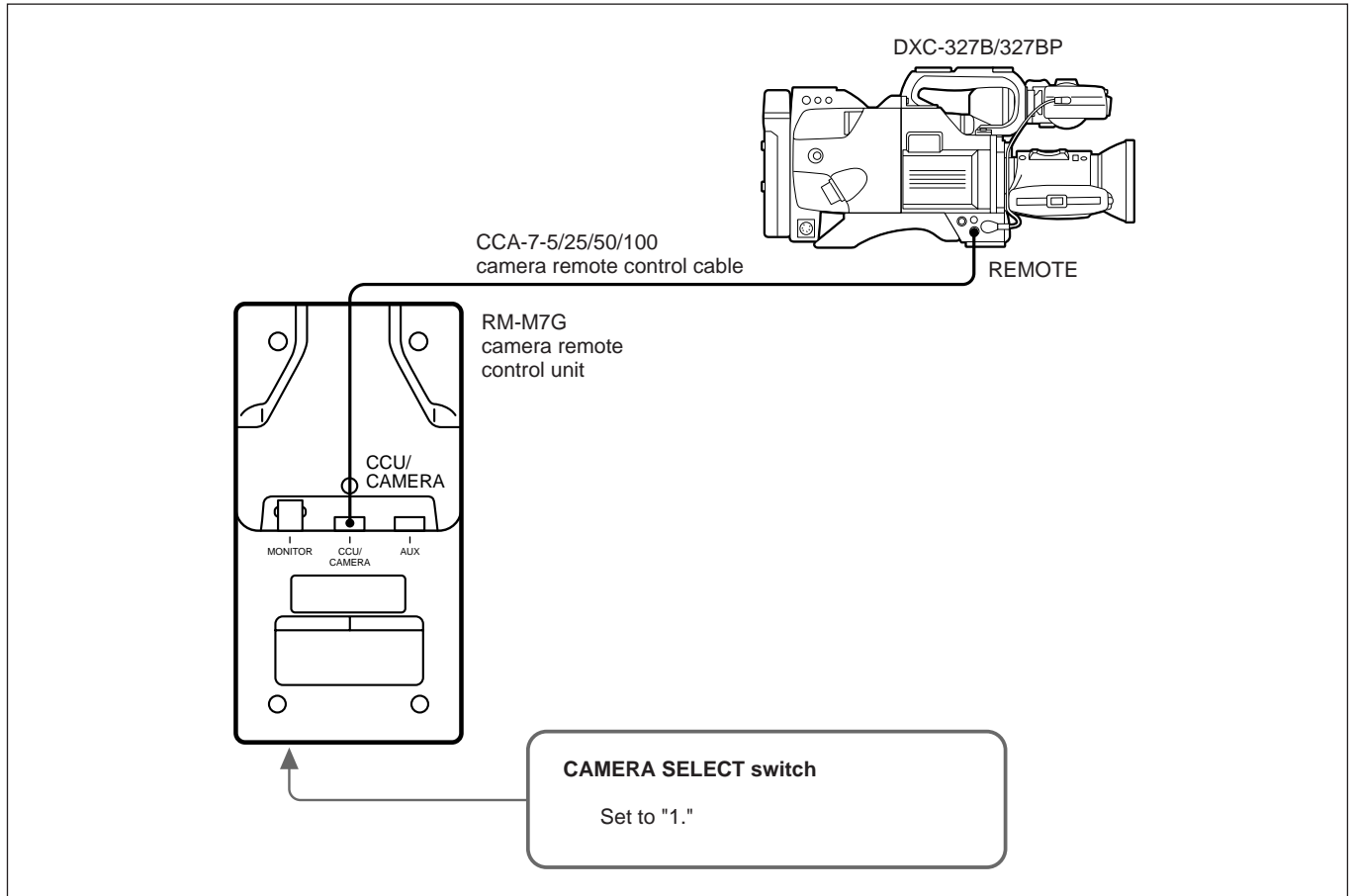

#### Notes on use with the RM-M7G

- Set the CAMERA SELECT switch on the RM-M7G to "1".
- When the camera is connected to a RM-M7G, the GAMMA and KNEE controls of the RM-M7G do not affect the video output signal neither the output signal from the TEST connector of the camera.
- The following switches on the camera do not function.
  - GAIN selector
  - WHITE BAL selector
  - SHUTTER switch
  - BARS switch
  - ABL switch

## Using the Camera with a VTR

When the DXC-327B/327BP is used with the CA-537/537P, the following VTRs can be used with this camera system.

Depending on the VTR connected to the camera, the switch setting on the camera adaptor, the usable cable, and the functions of the camera and the VTR vary. (Please consult your local authorized Sony dealer if you want to use a VTR other than those shown in the table below.)

### Setting of the VTR SELECT switch on the CA-537/537P

Set the VTR SELECT switch on the CA-537/537P depending on the VTR to be connected. If the setting is not correct, video and audio signals may not be recorded normally.

Connected VTR	Setting of the VTR SELECT switch (Output video signal)	Setting of the microphone output level
Sony BVW-35/35P/50/50P	1 (Composite)	-60 dB
Sony VO-8800/8800PS	3 (Y/C)	-60 dB
VHS format VTR AG-6400 (Panasonic)	2 (Composite)	-20 dB
S-VHS format VTR AG-7400 (Panasonic) JVC BR-S405	3 (Y/C)	-20 dB

#### Notes

- When the VO-6800/6800PS portable VTR is connected to the camera, set the -20 dB/-60 dB camera microphone input selector on the VTR to -60 dB.
- When a CCU-M5/M5P/M7/M7P Camera Control Unit is used, be sure to set the VTR SELECT switch to "1".

## Usable camera cables and power sources

Be sure to use the cable and AC power adaptor appropriate to the connected VTR.

Connected VTR	Connecting cable	Power supply from the VTR to the camera	AC power adaptor for the VTR
VO-8800/ 8800PS	CCZQ-nA	Yes	CMA-8A/8ACE
AG-6400 (Panasonic)	CCZJ-2	No	
AG-7400 (Panasonic)	CCZQ-nA	No	

#### Note

When the AG-6400/7400 is used, an independent power source must be provided for the camera.

## Connections

### Differences in functions

Available functions differs depending on the VTR connected as shown below.

Connected VTR	Remote control of VTR start/stop	REC/TALLY indicator		BATT alarm indication	Audio monitor (on the camera)	Picture shown on the viewfinder	
		REC indication	VTR alarm			During recording (picture from the camera)	During playback (picture from the VTR)
BVW-35/35P/50/50P	Yes	Yes	Yes	Yes	Yes	Yes	Yes
VO-8800/8800PS			No	No	No		
AG-6400 (Panasonic)					Yes		
AG-7400 (Panasonic)					Yes <sup>a)</sup>		

a) A picture from a VTR can be seen only when you press the RET button on the zoom lens.

# Power Sources

When the CA-537/537P Camera Adaptor is attached, the DXC-327B/327BP camera is powered by one of three types of power supply: external DC, battery DC, or AC power.

## Using a DC Power Supply

### Connecting to a DC power outlet

Connect a connecting cable from the DC IN connector on the camera adaptor or on a VTR to the external power source of 12 V DC.

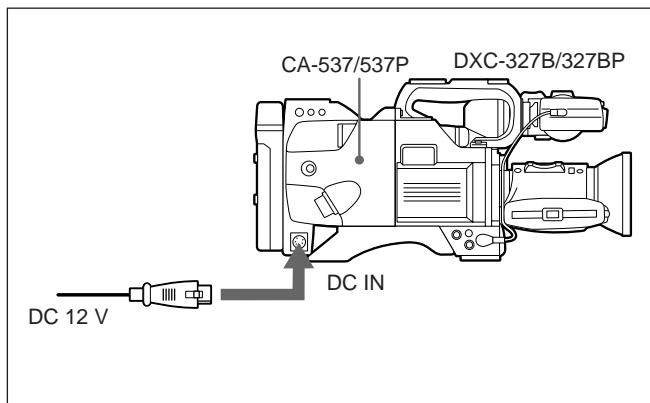

## Power Sources

### Using a Battery Pack

Before using the battery pack, recharge the battery (see “Charging the battery” on the next page).

#### Installing the battery pack

- 1 Press the button at the side of the battery case lid and pull open the lid.

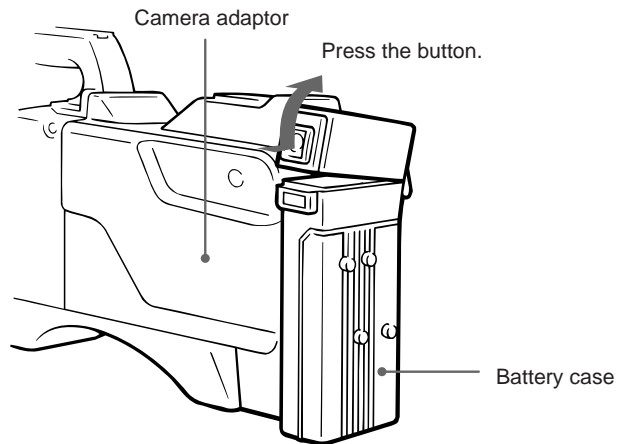

- 2 Slide the battery into the battery case with the arrow on the battery pack pointing downward.

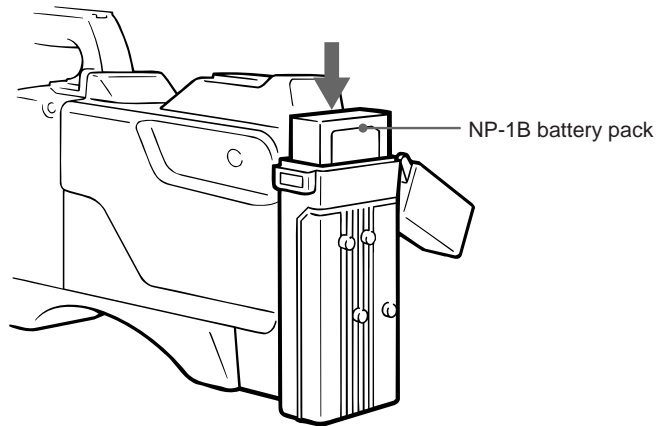

---

## Continuous battery operation time

When a camera adaptor is attached, the fully charged battery pack can continuously power the camera and viewfinder for a certain amount of time (see the table below). However, with the EVV-9000/9000P Videocassette Recorder attached, battery life is shortened.

Battery type	Battery life with CA-537/537P attached	Battery life with EVV-9000/9000P attached	Battery life with PVV-3/3P attached
NP-1B	About 135 min.	About 85 min.	About 80 min.
BP-90A <sup>a)</sup>	b)	About 180 min.	About 170 min.

- a) To use the BP-90A, a DC-500 Battery Case is necessary. The BP-90A cannot be used with a camera adaptor.  
b) A DC-500 Battery Case cannot be attached to the CA-537/537P/327/327P Camera Adaptor.

---

## Battery life warning

When the battery is nearly exhausted, the warning “BATT XX.XV” appears on the viewfinder screen showing the voltage level in the “XX.X”. If you continue to operate the equipment without changing the battery, the BATT indicator of the viewfinder also lights up to indicate that the battery must be replaced immediately.

---

## Charging the battery

Recharge the battery pack before each use using the battery charger shown in the table below.

Battery pack	Battery charger	Charging time
NP-1B	BC-1WD, BC-410	About 95 minutes
BP-90A	BC-410	About 160 minutes

## Power Sources

### Using Power Supplied Through the Camera Adaptor

To use the following equipment, make sure you have attached a CA-537/537P Camera Adaptor.

### Using a portable VTR

Connect the VTR/CCU/CMA connector on the camera adaptor and the VTR 14-pin Q-type camera connector on the VTR using the optional CCZQ Camera Cable. Then the power is automatically supplied from the VTR to the camera.

For the power source for the VTR, refer to the operations manual for the VTR.

See the connecting diagram for “Connecting a Portable VTR” (page 33).

#### Note

Before operating the camera, make sure that the power supplied from the VTR to the camera is sufficient. If the power supply capacity of the VTR is not sufficient, the camera must be powered independently.

### Note on the operating time

The continuous operating time depends on the operation on the VTR. Fast-forwarding or rewinding tape may reduce the operating time.

### Battery life indication

The life of the batteries installed in the portable VTR is indicated by the BATT indicator on the viewfinder. If the BATT indicator starts flashing, replace the battery with the charged one. If the camera continues operating without replacing a battery, the BATT indicator will stay lit. On some VTRs, the battery life is not indicated. (See page 38.)

### Using a CCU-M5/M5P and CCU-M7/M7P camera control unit

Connect the camera control unit and the VTR/CCU/CMA connector on the camera adaptor using the optional camera cable. Then the power is automatically supplied to the camera. (See page 34.)

### Using a CMA-8A/8ACE camera adaptor

Connect the CMA-8A/8ACE Camera Adaptor and the VTR/CCU/CMA connector on the camera adaptor using the optional camera cable. Then the power is automatically supplied to the camera. (See page 34.)

### Priority of power sources

When two or three power sources are simultaneously connected to the camera, the camera operation only uses one of the power supplies according to the numerical priority listed below (starting with DC power first). The other power sources are automatically cut off.

Type of power (priority)	supplied (on the camera adaptor) via the
1. DC power	DC IN connector
2. NP-1B battery	Battery pack compartment
3. AC power	VTR/CCU/CMA connector

When the EVV-9000/9000P Hi8 format VTR or the PVV-1/1P/1A/1AP/3/3P Betacam format VTR is attached, the camera operates on one of the two types of power sources according to the numerical priority listed below.

Type of power (priority)	supplied (on the VTR) via the
1. DC power	DC IN connector
2. NP-1B battery	Battery pack compartment

# Basic Operations

The following is the basic procedure for operating the camera. To get the most out of the videotaping operation, we recommend you do the adjustments and settings on the following pages.

## Operating the Camera

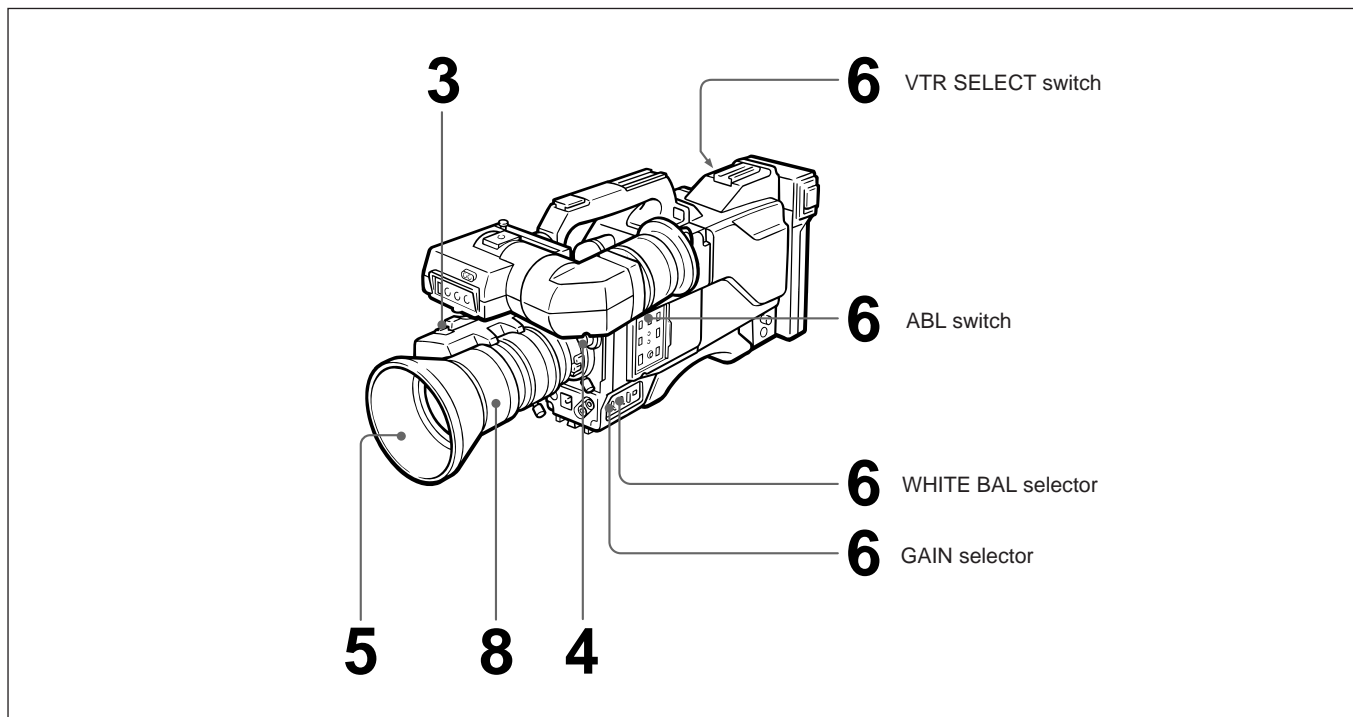

- 1** Check that equipment connections, such as to the VTR, are correct (see pages 32 to 36).
- 2** Turn the power switches to the camera and the all the connected equipment to the ON position.
- 3** Set the IRIS selector on the zoom lens to "A" (see page 52).
- 4** Select the appropriate position for the FILTER selector for the ambient lighting (see page 54).
- 5** Remove the lens cap.
- 6** Set the following switches:
  - ABL switch: OFF
  - GAIN selector: 0 dB
  - WHITE BAL selector: A or B (see page 56)
  - VTR SELECT switch (on the camera adaptor): corresponding to the VTR used
- 7** Point the camera at an object that is at least one meter (3 1/2 feet) from the lens.
- 8** Adjust the focus by turning the focus ring while looking at the image on the monitor or viewfinder screen.

### Recording with a Portable VTR

- 1** Turn the power switches to the camera and connected equipment to the ON position.
- 2** Set the VTR to Record Standby mode.
- 3** Adjust the black balance and white balance. (For details on how to do this, see “Adjusting the Black Balance,” page 55 and “Adjusting the White Balance,” page 56.)
- 4** Point the camera at a reference object and adjust the lens.  
Adjust the Iris (see page 52)  
Zoom (see page 60)  
Close-Up Function (see page 62)  
Focus
- 5** To start recording, press the VTR button on the camera, the VTR START/RETURN VIDEO button on the camera adaptor, or the VTR button on the lens.  
The REC/TALLY indicator in the viewfinder lights up during recording.
- 6** To stop recording, press the VTR START/RETURN VIDEO button or the VTR button used in Step 5 above.

### Recording with a Table-Top VTR

To record using a table-top VTR, follow the procedure explained for recording with a portable VTR except for the following:

- Start and stop recording using the function buttons on the VTR.
- The REC/TALLY indicator in the viewfinder does not function.
- The return video and the playback picture cannot be monitored on the viewfinder screen.

---

## Monitoring the VTR Picture and Audio Output

You can see the following three types of images on the viewfinder screen when the camera and the VTR are connected with the CCZQ camera cable. Note, however, that with some types of VTRs, you may not be able to monitor a picture. (For more details on the pictures which can be seen on the viewfinder screen, see the “Differences in functions” on page 38).

---

### A picture picked up by the camera (during recording)

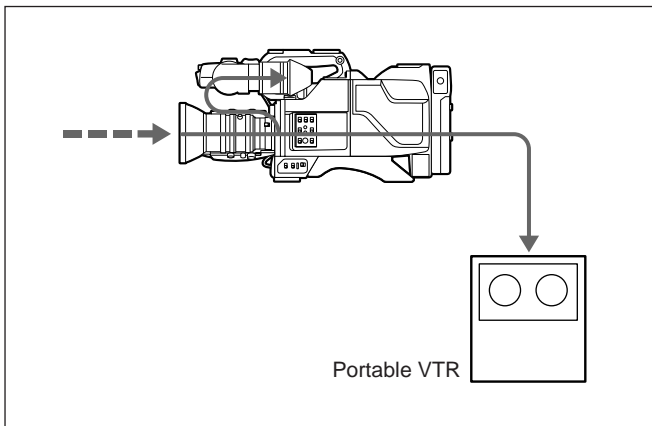

---

### An E-E mode picture from the VTR (when the RET button on the lens is pressed during recording)

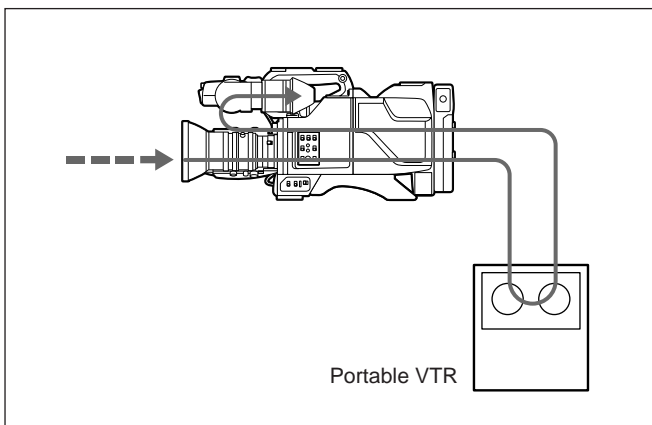

---

### A playback picture (during playback)

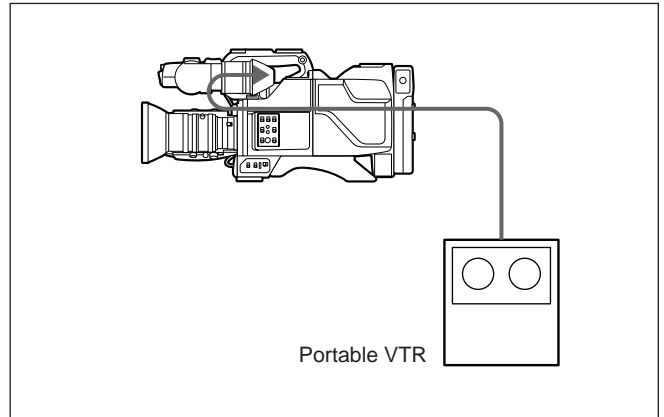

---

### Noise on the monitoring

While the playback picture from the VTR displays on the viewfinder screen, some of the video signals output from the camera such as the sync signal, may mix with the playback picture so that streaks of noise roll horizontally or vertically across the screen.

---

### Monitoring the audio output

You can monitor the audio signal during recording and reviewing by connecting an earphone to the EARPHONE jack on the camera adaptor. Note, however, that with some types of VTR, you may not be able to monitor the audio output.

# Adjustment and Settings

In the electronic viewfinder, the viewfinder screen itself shows you the settings of switches such as black/white balance and gain. At the periphery of the screen the viewfinder indicators show the status of operations such as battery level.

## Reading Indications in the Electronic Viewfinder

### Viewfinder screen and status indicators

Four indicators (see illustration below) correspond to the status of the camera and connected equipment.

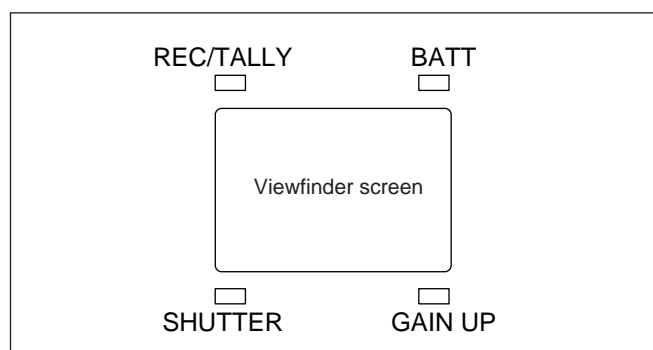

Indicator	Operates when...	Blinks	Lights up
REC/ TALLY	While recording, using a VTR connected with a CCZQ-A camera cable	Until the VTR enters the standby mode	During recording
	While using a VTR (equipped with a warning system), which is connected with a CCZQ-A camera cable	While the VTR is malfunction	—
	While using the CCU-M5/M5P/M7/M7P	—	When this camera is selected
BATT	While the camera is powered by the battery pack	—	When the battery power becomes weak
	When a VTR is connected to the camera	When the battery power becomes weak	If you keep on operating the connected equipment after the indicator starts blinking
SHUTTER	Any time	—	When the SHUTTER switch of the camera is set to ON
GAIN UP	Any time	—	When the GAIN selector is set to 9 dB or 18 dB

---

## Reading warning indications on the viewfinder display

Two indications, “LOW LIGHT” and “BATT 10.7V” appear on the viewfinder screen. The following explains what they mean and some possible remedies to the problems they indicate.

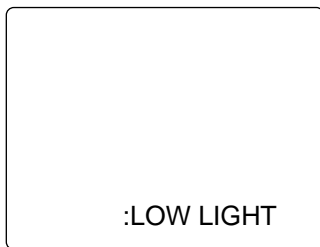

- Meaning** Lighting is insufficient.
- Remedy**
- Increase the ambient lighting.
  - Open the iris manually or activate the automatic iris function.
  - Select an appropriate filter.
  - Set the GAIN selector to 9 dB or 18 dB.
  - Set the SHUTTER switch to OFF.

It is possible to switch the “LOW LIGHT” indication on or off.

**On:** Press the UP/ON button when the character display is in the current camera setting (see next page) mode.

**Off:** Press the DOWN/OFF button when the character display is in the current camera setting (see next page) mode.

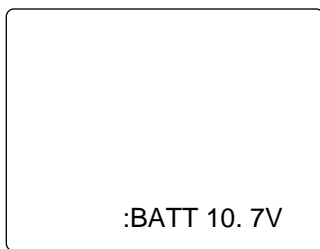

- Meaning** The input voltage to the camera is about 10.7 volts.
- Remedy** Replace the battery with a fully charged one.

If you continue recording with a weak battery, the quality of the recording will deteriorate.

---

## When the camera is used with the PVV-3/3P

The data of the PVV-3/3P such as time code, user's bit, tape counter, etc. cannot be displayed on the viewfinder screen.

# Adjustment and Settings

## Current settings

The viewfinder screen shows you the settings of the switches on the camera head, camera adaptor, and zoom lens. If necessary, change the settings using the procedures described in this section and the table below.

Press the DISP CHG switch several times until the following (see illustration below) display appears on the viewfinder screen.

The following table explains the meanings of the below screen display items.

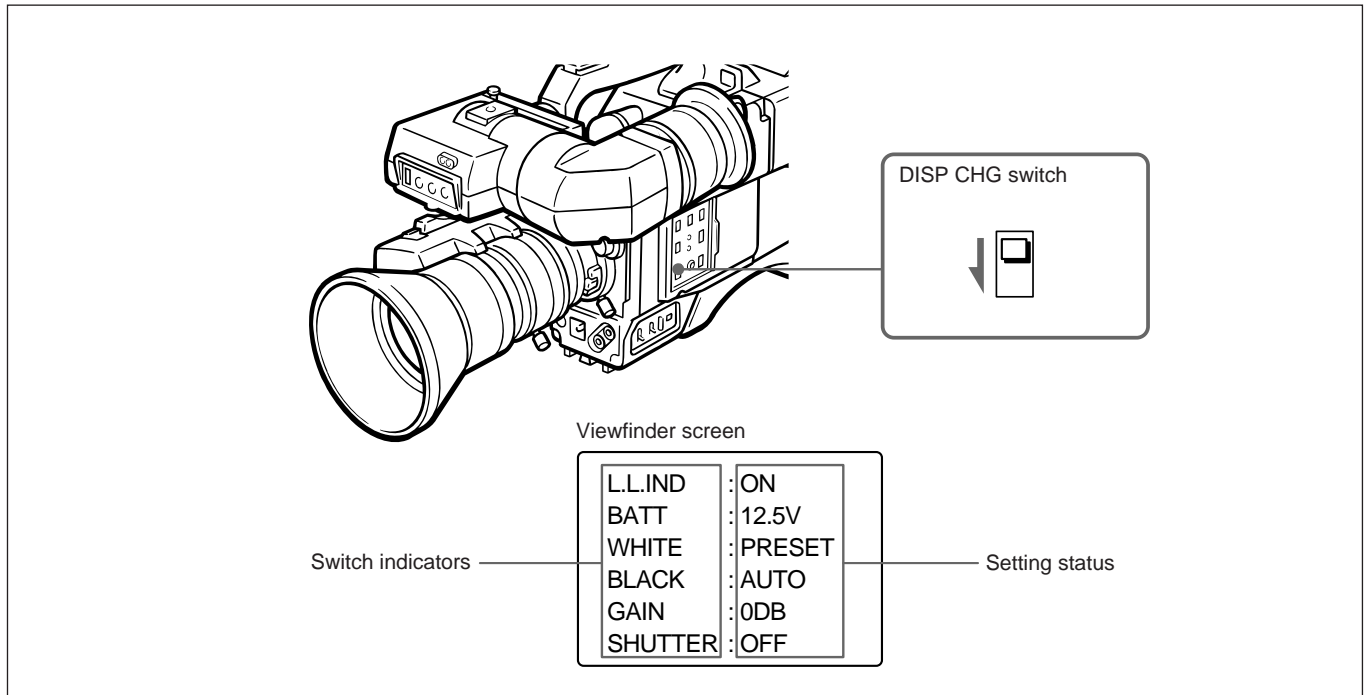

Switch indicators	Meaning	Setting Status	Meaning
L.L. IND	Setting the "LOW LIGHT" indication	ON	"LOW LIGHT" is displayed.
		OFF	"LOW LIGHT" is not displayed.
BATT	Battery voltage	XX.XV	The battery voltage level is displayed.
WHITE	White balance adjustment mode	PRESET	For the factory preset value
		AUTO/A or AUTO/B	For automatic adjustment. (The white balance has been adjusted automatically using the volume stored in memory A or B.)
		MANUAL	For manual adjustment using the CCU-M7/M7P, CCU-M5/M5P Camera Control Unit, or RM-M7G Camera Remote Control Unit.
BLACK	Black balance adjustment	AUTO	For automatic adjustment
		MANUAL	For manual adjustment using the CCU-M7/M7P, CCU-M5/M5P Camera Control Unit, or RM-M7G Camera Remote Control Unit.
GAIN	Setting the video output level	0 DB, 9 DB, 18 DB	The video output level is 0 dB, 9 dB or 18 dB.
SHUTTER	Setting the shutter speed	OFF	The shutter speed cannot be changed.
		Shutter speed set	The set shutter speed is displayed.

## Reading the Viewfinder Screen Display Menu

The following chart shows how the display changes on the screen each time you press the DISP CHG switch. In all modes, the black balance and white balance can be adjusted automatically.

The display mode changes to the black balance or white balance adjustment mode during adjustment and returns to the selected display after the adjustment is complete.

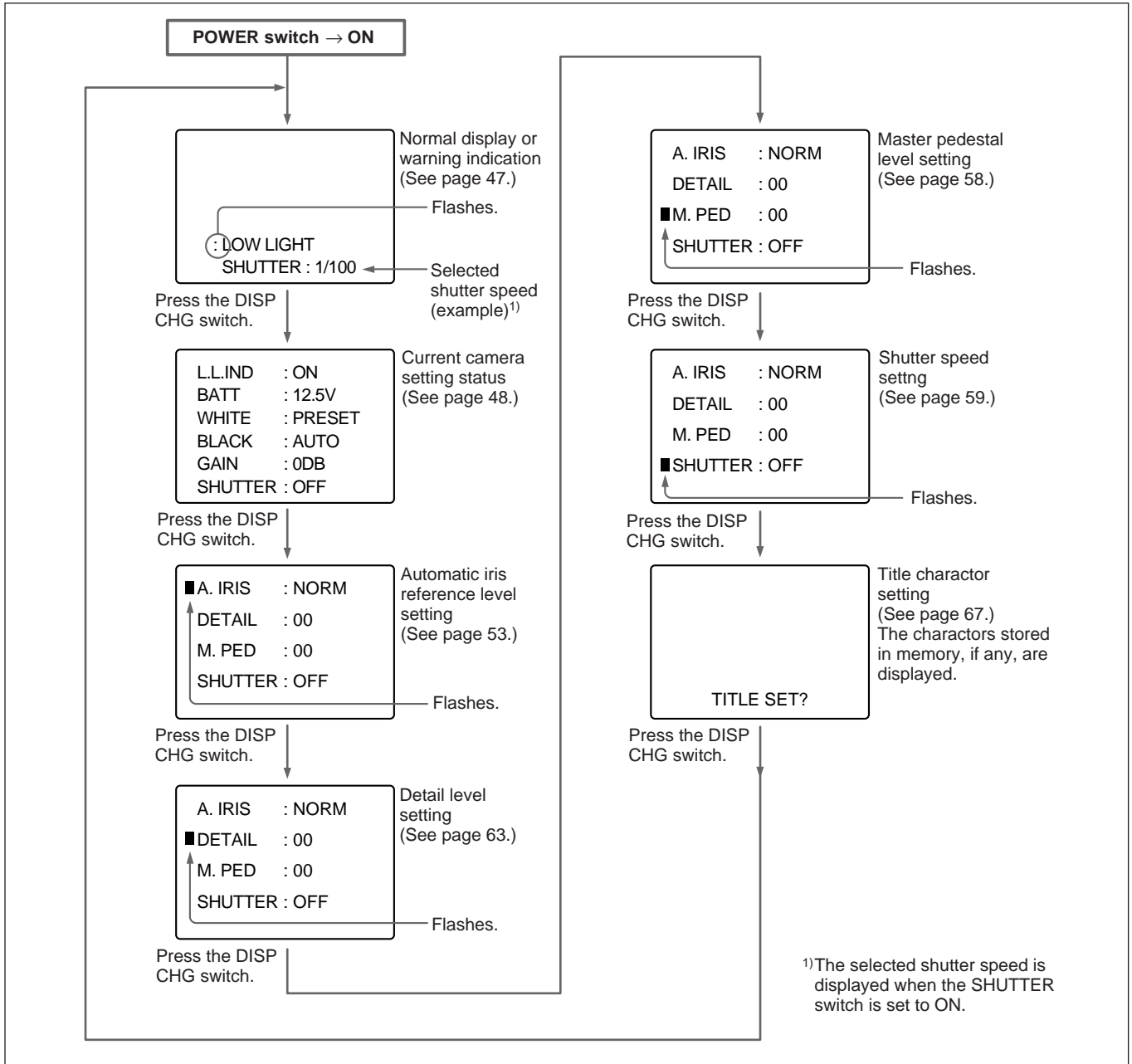

## Adjustment and Settings

---

### Adjusting the Viewfinder Screen Display

After adjusting the viewfinder and the eye cup, make the following adjustments so that the viewfinder screen can be seen comfortably.

Note, however, that none of these settings affect the video output signal of the camera.

---

### Adjusting the eyepiece focus

Because each eyesight of each individual is different, it may be necessary to adjust the diopter when a new camera operator uses the viewfinder.

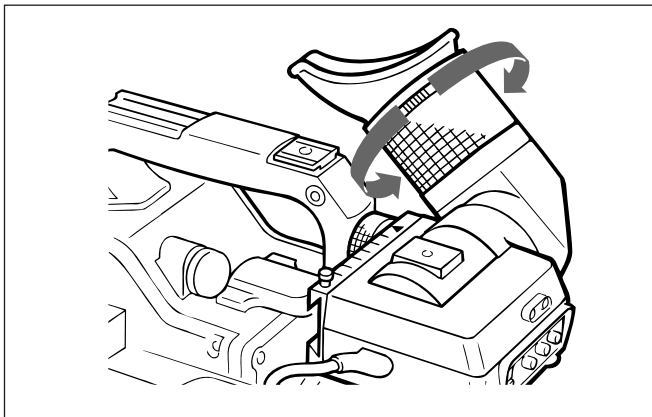

- 1** Focus the lens.
- 2** Turn the diopter ring (see illustration above) within the range of  $-0D$  to  $-3D$  until the view is clear. The adjustable range can be changed to that of  $-2$  to  $+1 D$  or  $-0.5$  to  $+3D$ . Consult your Sony dealer.

---

### Adjusting the contrast and brightness on the viewfinder

- 1** Set the BARS switch on the camera to ON.
- 2** Adjust the contrast and brightness using the CONTRAST and BRIGHT controls on the viewfinder while referring to the color bar signals on the viewfinder screen.
- 3** Set the BARS switch to OFF after adjustment.

---

### Adjusting the outline emphasis

Turning the PEAKING control changes the degree of outline emphasis in the viewfinder image, to make focusing easier.

---

## Adjusting the Video Monitor

When you are using a color video monitor to monitor the video output, adjust the color on the monitor using the procedure that follows. (See the section, “Connecting an S-VHS Format Portable VTR” on page 32 for information on how to connect a video monitor and a VTR.)

- 1** Set the BARS switch to ON.
- 2** Adjust the color and hue controls on the monitor while viewing the color bars on the monitor screen.
- 3** Set the BARS switch to OFF.

# Adjustment and Settings

## Adjusting the Iris

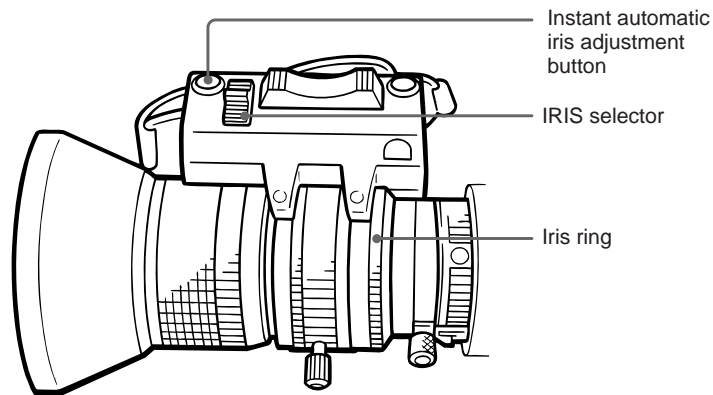

### Automatic iris adjustment

Set the IRIS selector to “A.” This is the normal setting for the automatic iris.

This setting makes the iris automatically adjust to the brightness of the object being shot.

### Adjusting the iris manually

Use manual adjustment when recording an object against a bright sky or a scene with high contrast.

Set the IRIS selector to “M.”

### Using the zebra pattern for iris adjustment

The zebra pattern appears on the portion of the screen where the video output is about 70 to 80% IRE (NTSC) or 490 to 560 mV (PAL). This pattern acts as a reference when you manually adjust the iris. (For the procedure, see “Checking the Video Level,” page 64.)

### Temporary automatic adjustment

- 1** To automatically adjust the iris while the IRIS selector is set to “M”, keep the Instant Automatic Iris Adjustment (IAIA) button depressed.
- 2** To fix the iris value that was set in Step 1, release the IAIA button. The iris remains fixed at this value until it is manually adjusted again.

## Selecting the automatic iris reference level

When adjusting the video level of a back-lit subject, you can change the automatic iris reference level setting. When you make the setting, it is retained in the memory of the camera.

The selectable values are as follows:

- -1.0
- -0.5
- NORMAL (reference value)
- 0.5
- 1.0

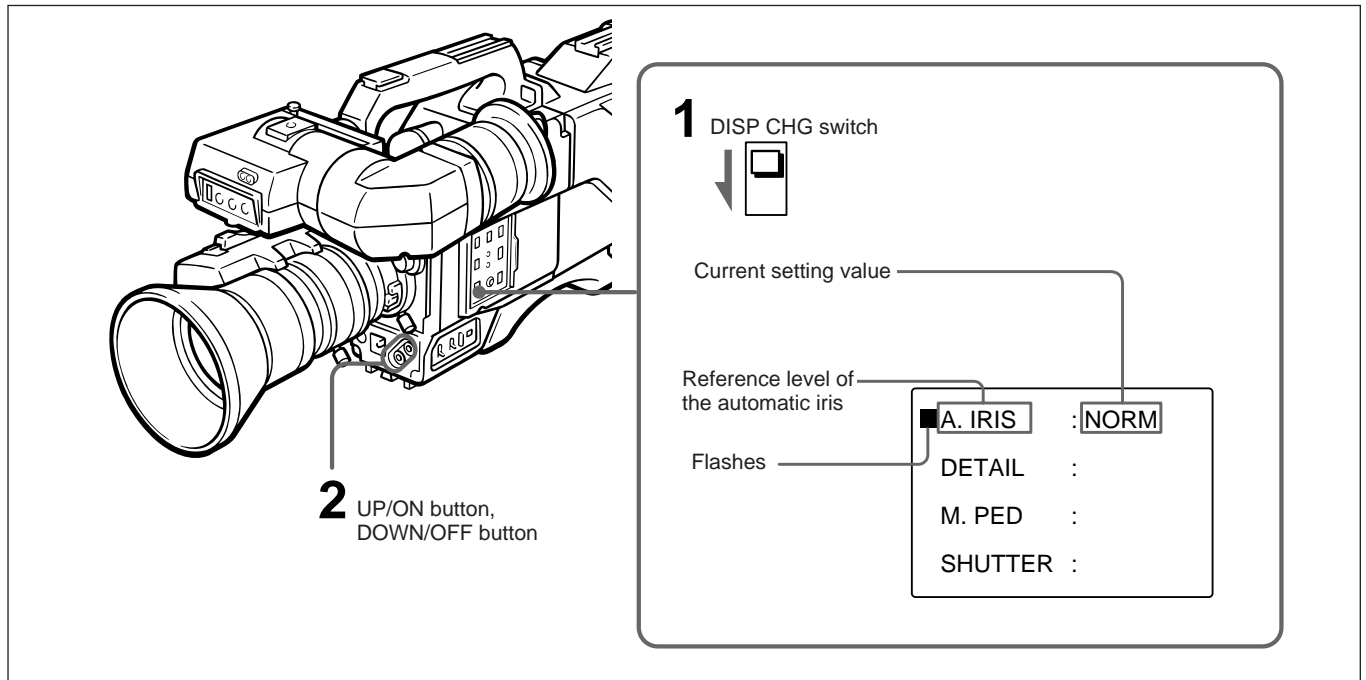

**1** To select the automatic iris reference level, press the DISP CHG switch several times until the above display appears on the viewfinder screen.

**2** Select the setting value (from -1.0 to 1.0).

**To raise the value:** Press the UP/ON button

**To lower the value:** Press the DOWN/OFF button

**To reset to NORMAL:** Press the UP/ON and DOWN/OFF buttons simultaneously

### Note

When you connect the CCU-M7/M7P, CCU-M5/M5P Camera Control Unit, or RM-M7G Camera Remote Control Unit to the camera, change the automatic iris reference level using the controls on the CCU-M7/M7P, CCU-M5/M5P, or RM-M7G. The controls on the camera do not operate this function.

# Adjustment and Settings

## Selecting the Filter

The color temperature changes according to lighting conditions. To compensate for this, use one of the color temperature conversion filters indicated in the table below. Turn the dial (see illustration below) to the correct filter number.

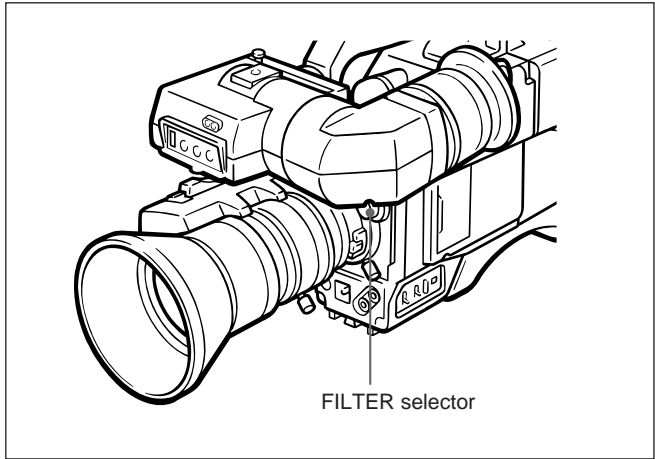

Filter number	Color temperature	Lighting conditions
1	3200K	Iodine lamp, sunrise or sunset
2	5600K+1/16ND <sup>1)</sup>	Bright outdoor
3	5600K	Cloudy or rainy

1) ND: Neutral Density filter

## Using an ND filter

Exceptionally bright scenes such as a sunny day at the beach or snow-covered terrain will look “washed out” when videotaped. To videotape these scenes naturally, set the FILTER selector to the “2” position. If the scenes are still too bright with the FILTER selector set to the “2” position, use an ND filter available in the market.

Use the above table as a guide for selecting the correct filter.

For attaching an ND filter, see “Attaching an optional filter” on page 26.

## Adjusting the Black Balance

Adjust the black balance to ensure picture clarity and life-like color reproduction.

When adjusting the black balance, the black set is adjusted simultaneously. The adjusted black balance value is retained in the memory of the camera and you need not re-adjust it later except for the cases mentioned later:

### Before You Begin

- Check that the W/B BALANCE switch on the camera control unit is not set to MANUAL. If it is set to MANUAL, you cannot adjust the black balance from the camera.
- Set the BARS switch to OFF so that the normal video signal outputs. If the video camera is outputting a color bar signal, you cannot adjust the black balance. If you try to do so, the viewfinder screen displays the following message over the color bars:

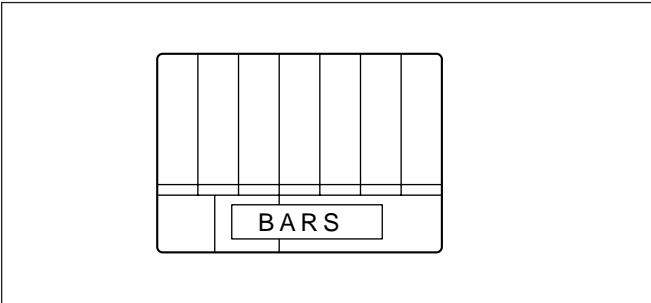

---

## Adjusting black balance

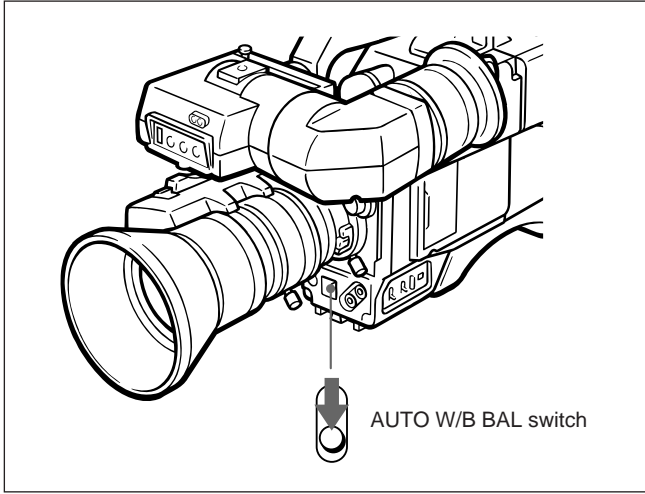

Flip the AUTO W/B BAL switch to the BLK position, and when you hear a click, release the switch.

“AUTO BLACK -OP-” appears on the viewfinder screen during adjustment, and “AUTO BLACK-OK-” appears on the viewfinder screen when adjustment is complete.

### If black balance cannot be done

The characters shown below are displayed on the viewfinder screen.

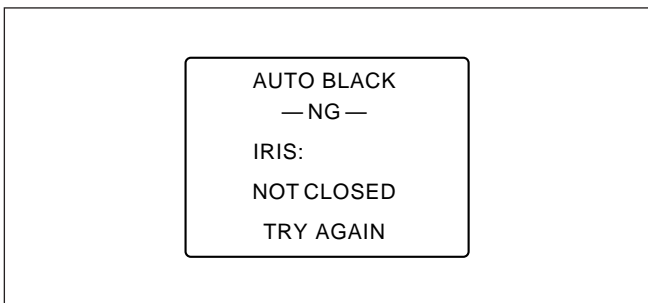

### When black balance adjustment is complete

During black balance adjustment, the iris is automatically closed. If the IRIS selector is set to “M”, you must open it manually to open it again.

---

## Re-adjust the black balance

The adjusted value is stored on the camera, and is kept even when the power is turned off. Normally readjustment is not required except for the following cases.

- “MEMORY NG” appears on the viewfinder screen.
- The camera has not been used for a long time.
- The ambient temperature has changed radically.

# Adjustment and Settings

## Adjusting the White Balance

The white balance should be adjusted so that a white object is reproduced as white and life-like color is obtained. The white balance changes depending on the lighting conditions.

The camera has two memories, A and B, in which to

store the adjusted white balance values. You can store two adjusted values under two different lighting conditions and recall either of the values according to ambient conditions.

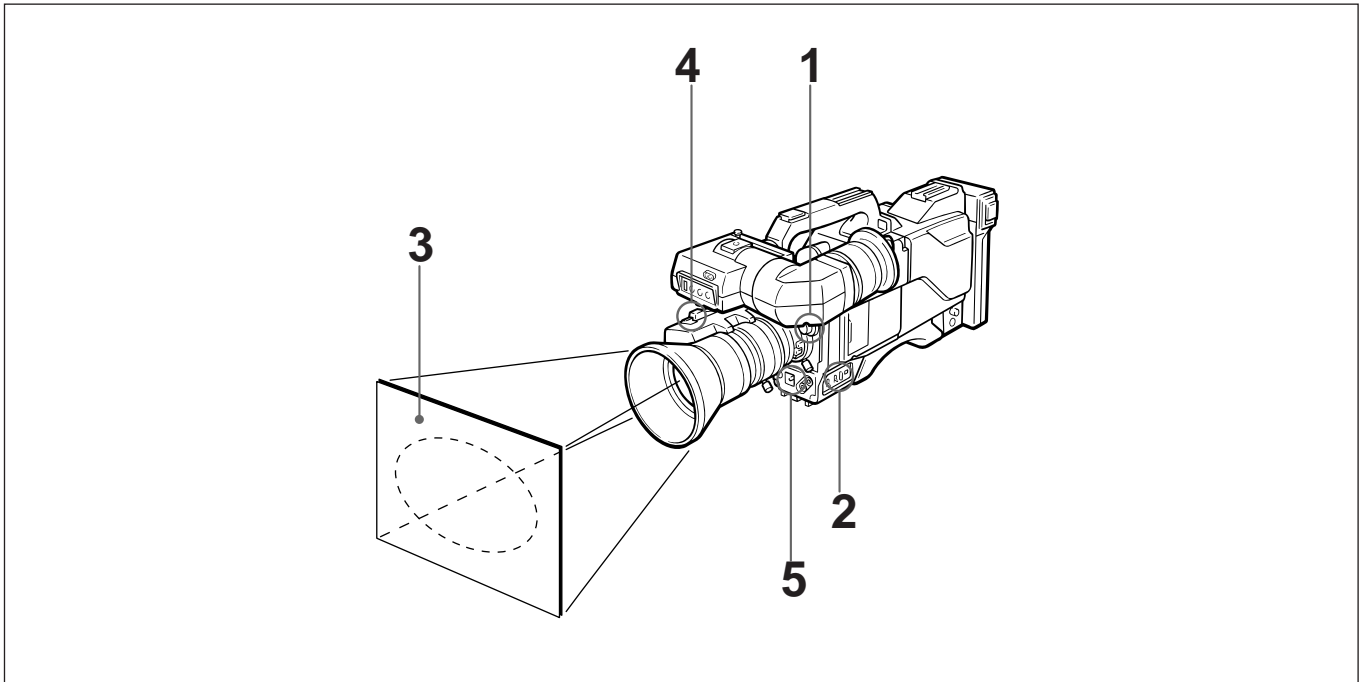

- 1** Select the position of the FILTER selector on the camera head according to lighting conditions.
- 2** Set the WHITE BAL selector to “A” or “B”.
- 3** Zoom up on a white object such as a white cloth or paper with the same lighting conditions as those for shooting. The minimum white area required for adjustment is as follows:
- 4** Set the IRIS selector on the lens to “A”.
- 5** Press the AUTO W/B BAL switch to the WHT position. When you hear a click, release the switch. “AUTO WHITE -OP-” appears on the display screen during adjustment, and “AUTO WHITE -OK-” appears on the viewfinder screen when adjustment ends. The camera stores the adjusted white balance value in the selected memory.

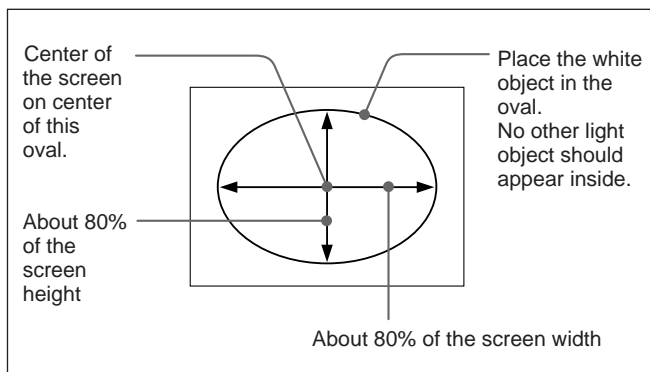

## When the white balance cannot be adjusted automatically

The following characters appear on the screen display if white balance cannot be adjusted automatically. Re-adjust the white balance after taking the measures required in the chart below.

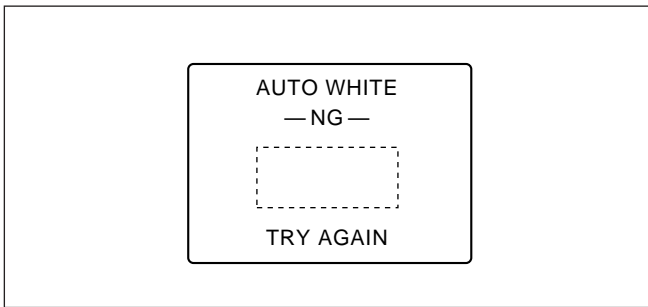

Display	Causes and measures
LOW LIGHT	Light is insufficient. Add illumination or raise the video output level with the GAIN selector
??	The object is not white or very bright light appears in the picture. Change the object to an appropriate one.
C. TEMP. LOW CHG. FILTER	Color temperature is too low. Select the appropriate filter with the FILTER selector.
C. TEMP. HI CHG. FILTER	Color temperature is too high. Select the appropriate filter with the FILTER selector.
WHITE: PRESET	When the WHITE BAL selector is set to the PRE position. Set to the A or B position.
WHITE: MANUAL	When the CCU is connected, and the manual white balance adjustment is selected on the CCU. Select to the automatically adjust.
BARS	When the color bar signal is output. Set the BARS switch to "OFF" position.

## When you have no time to adjust the white balance

- 1** Select the appropriate filter with the FILTER selector on the camera depending on the lighting conditions.
- 2** Set the WHITE BAL selector to PRE.  
You can obtain the approximate white balance.

## Readjustment

The adjusted value is kept even if the power is turned off. So readjustment is not required.

# Adjustment and Settings

## Adjusting the Contrast

To adjust the contrast, change the pedestal level. When the master pedestal level is raised, the dark portion of the picture brightens, and when the level is lowered, the corresponding portion darkens. You can

change the level from about -30% to +30% of reference level (0.7 V) in increments of 1%. The adjusted master pedestal level is kept in the memory of the camera.

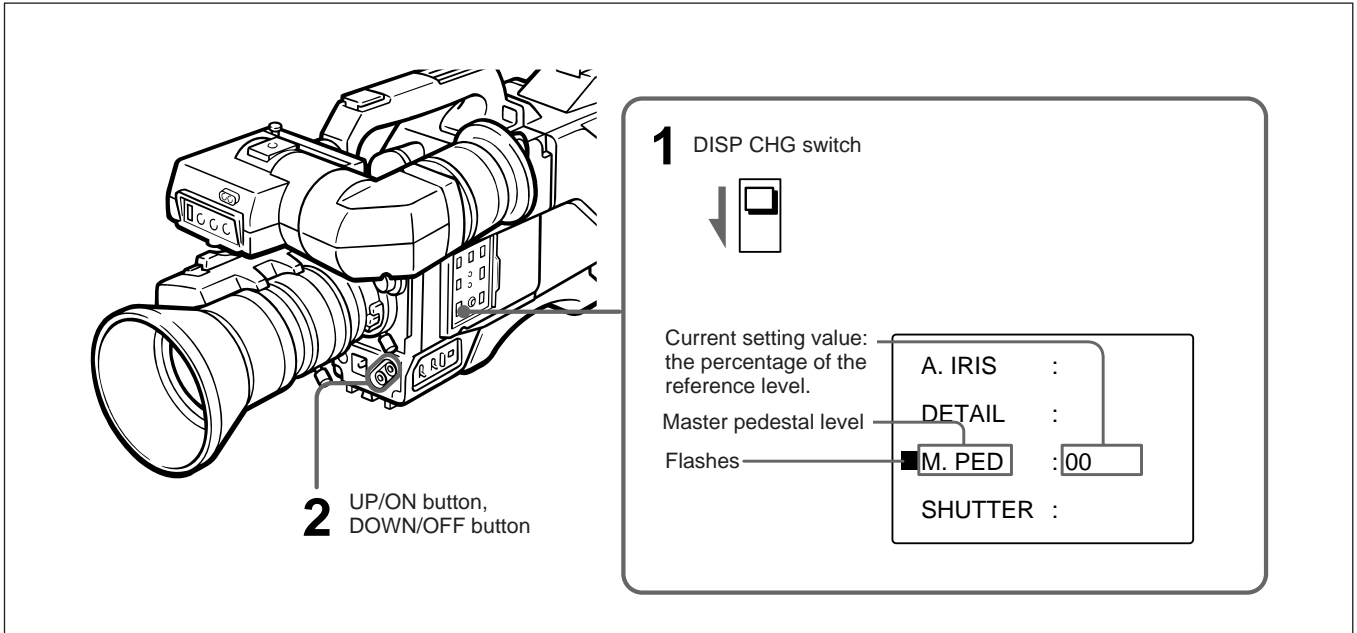

- 1 Press the DISP CHG switch several times until the display above appears on the viewfinder screen.
- 2 Change the master pedestal.  
**To raise the level:** Press the UP/ON button on the camera head.  
**To lower the level:** Press the DOWN/OFF button on the camera head.  
**To reset the level to the reference level:** Press the UP/ON and DOWN/OFF buttons simultaneously.

### Notes

- If the CCU-M7/M7P, CCU-M5/M5P Camera Control Unit or RM-M7G Camera Remote Control Unit is connected to the camera, set the master pedestal level from the CCU or RM-M7G. It cannot be set on the camera.
- To check the master pedestal level on a waveform monitor during adjustment, set the ABL switch on the camera to OFF. When the ABL switch is set to ON, appropriate waveform will not appear on the monitor screen.

## Selecting the Shutter Speed

The shutter speed is factory set to 1/100 for NTSC and 1/60 for PAL. You can change the shutter speed if necessary. Select the shutter speed from the following:

For NTSC: 1/100, 1/250, 1/500, 1/1000, 1/2000

For PAL: 1/60<sup>1)</sup>, 1/250, 1/500, 1/1000, 1/2000.

Your selection is retained in the memory of the camera.

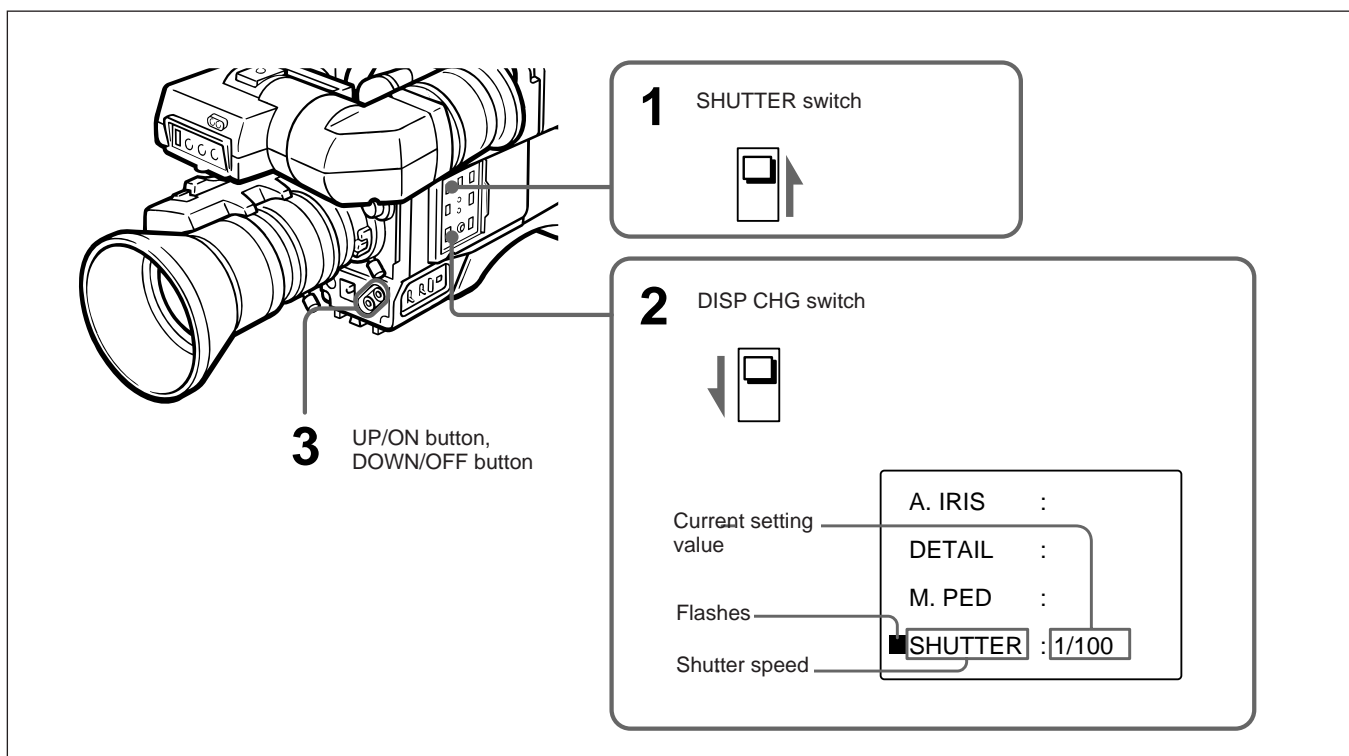

**1** To change the shutter speed, set the SHUTTER switch on the camera to ON.

**2** Press the DISP CHG switch several times until the display above appears on the display screen. If the SHUTTER switch is set to OFF, “OFF” appears at the current setting value.

**3** Select the shutter speed.

**To increase the shutter speed value:** Press the UP/ON button on the camera head.

**To decrease the value:** Press the DOWN/OFF button on the camera head.

**To reset the value to 1/100 (for NTSC) or 1/60 (for PAL):** Press the UP/ON and DOWN/OFF buttons simultaneously.

1) When you are using the RM-M7G to control the camera, the 1/100 setting on the RM-M7G sets the camera shutter speed to 1/60 and “1/60” appears on the screen display in the viewfinder. This is to prevent flickering when you are shooting a CRT screen.

# Advanced Operations

## Zoom Operation

You can go from wide angle to telephoto shots by using the motorized zoom or doing the zoom manually.

### Motorized zoom

Zooming at a constant speed is obtained.

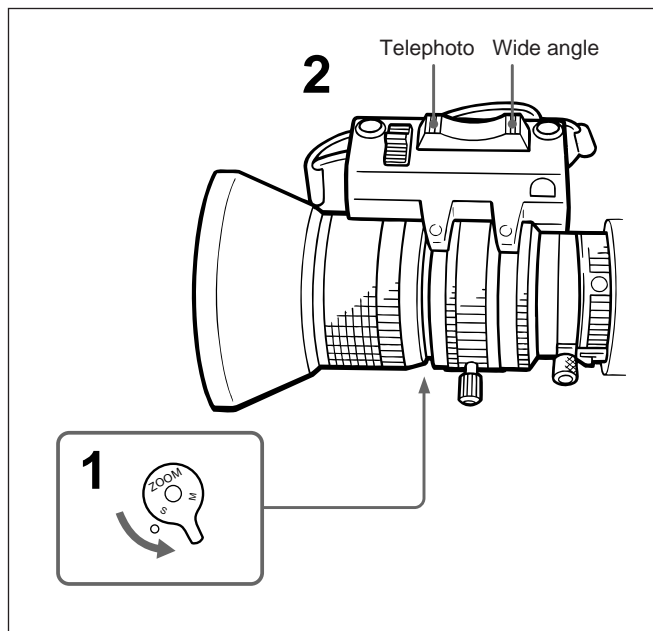

- 1 Set the ZOOM selector to the “S” (servo) position.
- 2 Press either end of the motorized zoom switch. To zoom faster, press all the way down on the motorized zoom switch. Press the switch lightly to zoom more slowly.

### Manual zoom

Manual zoom allows more precise control over the zooming speed.

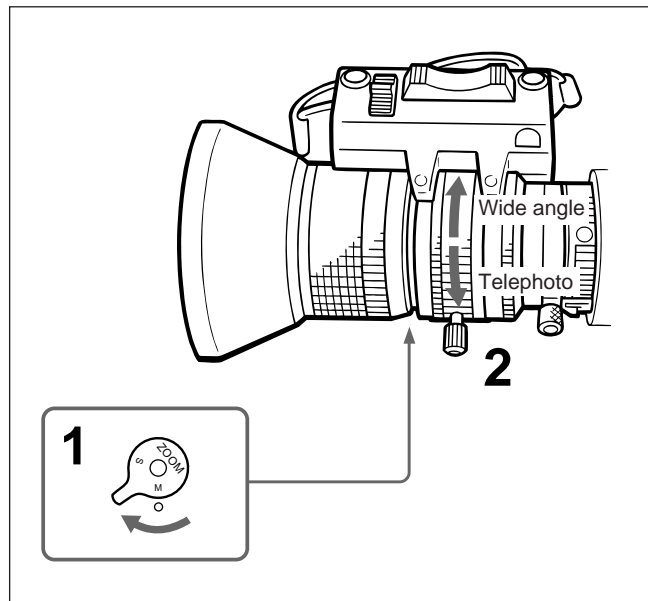

- 1 Set the ZOOM selector to the “M” (manual) position.
- 2 Position the Manual zoom lever to the appropriate angle.

### Tips on using the zoom

#### Correct focusing

If the subject is in focus in the telephoto position, it will remain in focus when you zoom back to wide angle.

#### For a more stable picture

We recommend placing the camera on a tripod when using the zoom. If you zoom with the camera on your shoulder, stand as steadily as possible.

#### Positioning the object at the center of the screen

For zoom-in, adjust the focus in the telephoto position, and set to the wide angle position. Then start to zoom in. Make sure that the object stays at the center of the screen while you are using the zooming.

## Adjusting Flange Focal Length

The proper flange focal length adjustment ensures that the object is in focus both at the wide-angle and telephoto position when using the zoom. Once you have made the flange focal length adjustment, you do not have to re-adjust the lens as long as the lens stays on the same camera.

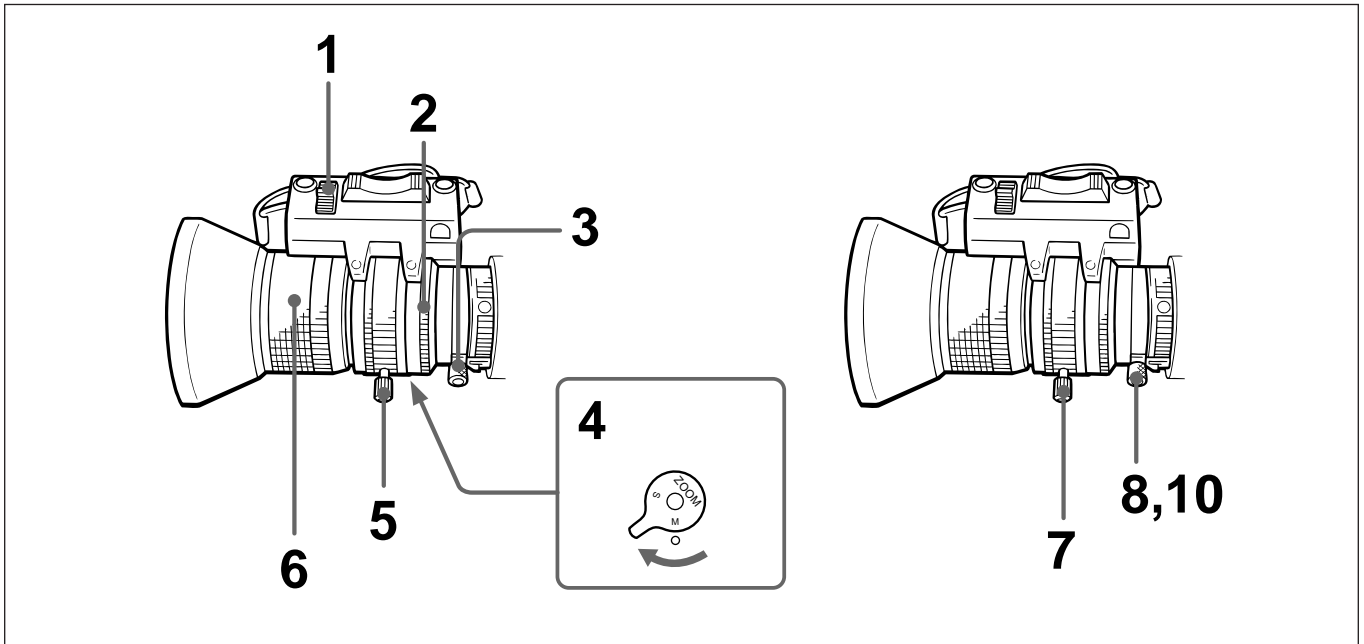

- 1** To adjust the focal flange, set the IRIS selector to M.
- 2** Set the iris ring to 1.4.  
Position the supplied chart for iris adjustment and illuminate the chart so that the proper video level is reached when the iris ring is at 1.4.
- 3** Loosen the screw on the Ff adjustment ring.
- 4** Set the ZOOM selector to M.
- 5** Turn the manual zoom lever to 105, telephoto position.
- 6** Turn the focus ring until the chart is in focus at about three meters (10 feet) from the lens.
- 7** Turn the manual zoom lever to 7.5, wide-angle position.
- 8** Turn the Ff adjustment ring and focus on the chart used in Step 6.  
Do not turn the focus ring for focusing.
- 9** Repeat Steps 5 through 8 until the chart is in focus both at the telephoto position and at the wide-angle position.
- 10** Tighten the screw on the Ff adjustment ring firmly.

## Advanced Operations

### Doing Close-Ups

The close-up or macro function lets you zoom in on flowers, insects and even photographs. The minimum distance from the lens to the object is 10 mm in the 7.5 wide-angle zoom position.

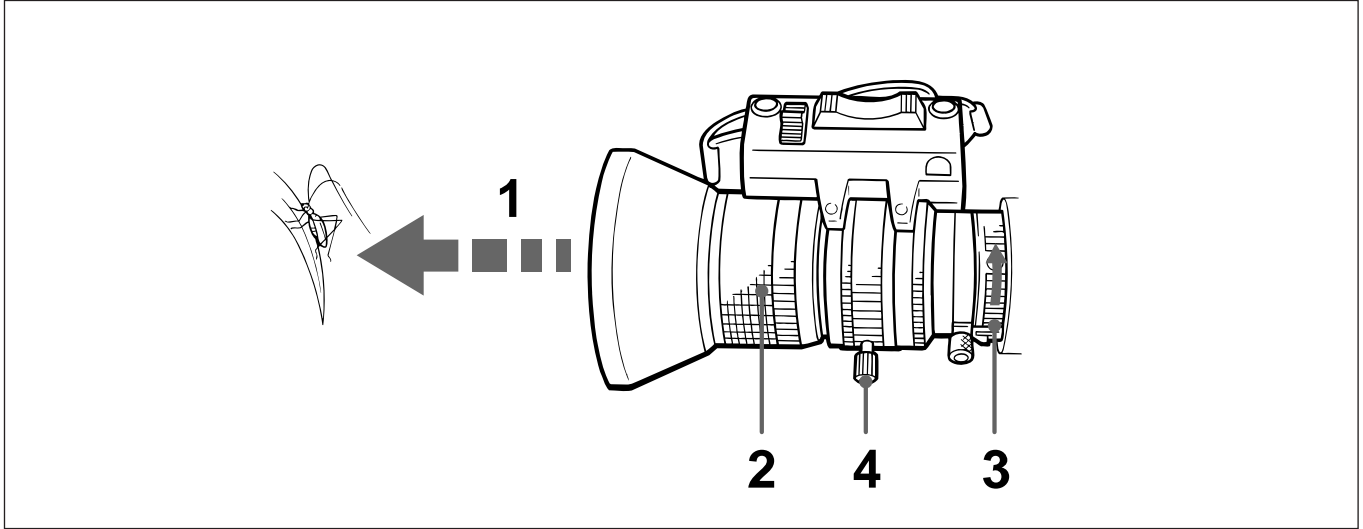

- 1** Adjust the distance between the lens and the object to get the desired image size.
- 2** Set the focus ring to the  $\infty$  (infinity) setting.
- 3** Turn the MACRO ring until it stops while pushing the button in the direction of the MACRO arrow.
- 4** Focus on the object by turning the manual zoom lever with the ZOOM selector set to M.
- 5** When the close-up operation is complete, return the MACRO ring to its original position.

#### To reduce the object size on the screen

Adjust the focus following steps 1 through 4 above, then turn the MACRO ring slightly toward its original position and adjust the focus with the manual zoom lever again.

#### Note on the focus ring

If the focus ring is set to  $\infty$  (infinity) while the MACRO ring is turned to "MACRO," the focus can be continually adjusted from the close-up position to  $\infty$  (infinity) with the manual zoom lever.

## Adjusting the Sharpness of the Picture

You can increase (harden) or decrease (soften) the sharpness of the picture. Change the value of the detail level to increase or decrease the sharpness. The detail level can be set from -99 to +99 of the factory-set reference level (00).

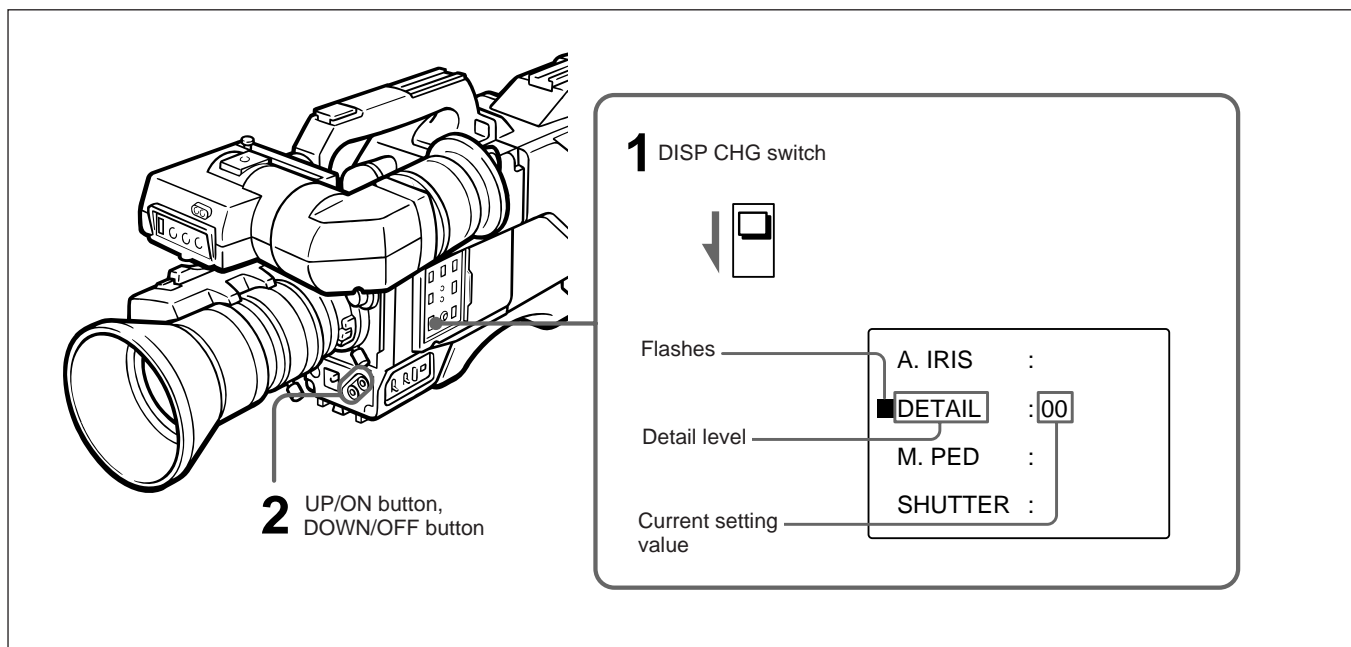

- 1** Press the DISP CHG switch several times until the above display appears on the viewfinder.
- 2** Change the value of the detail level.
  - To increase the value:** Press the UP/ON button on the camera head.
  - To decrease the value:** Press the DOWN/OFF button on the camera head.
  - To reset the value to the reference level:** Press the UP/ON and DOWN/OFF buttons simultaneously.

### Note

If you increase the video output level when you increase the detail level, the noise in the picture increases.

### When using the RM-M7G

When the RM-M7G Camera Remote Control is connected to the camera, the detail level can be changed from the RM-M7G.

## Advanced Operations

### Selecting the Output Level

If you cannot get a clear picture because of insufficient light, set the GAIN selector to a higher or lower position. (The GAIN selector is normally set to “0 dB”.)

The video output level can be raised by 9 dB by setting the GAIN selector to “9 dB” and by 18 dB by setting the selector to “18 dB”.

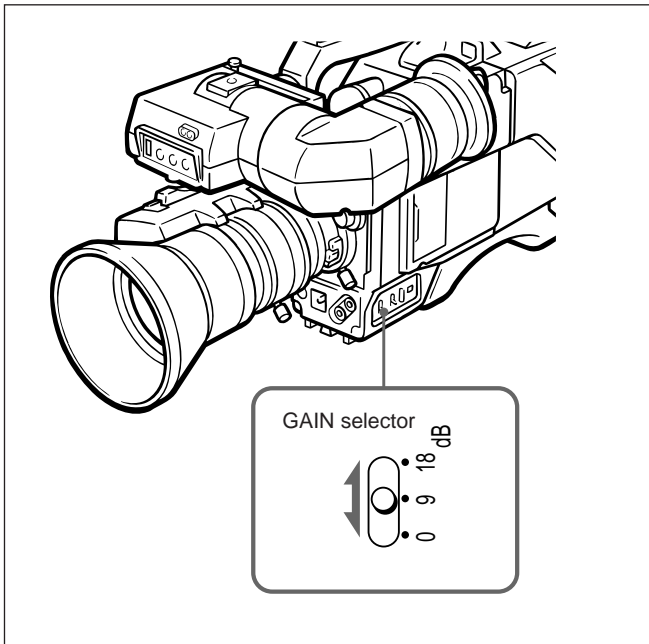

### Checking the Video Level

Use the zebra pattern (generated by the camera) as a reference when adjusting the iris manually. The zebra pattern indicates areas of the picture where the video level is approximately 70 to 80% IRE (for NTSC) or 490 mV to 560 mV (for PAL).

When the ZEBRA switch is set to ON, a zebra pattern appears on the part of the viewfinder screen where the video output level is 70 to 80% IRE or 490 to 560 mV. Adjust the iris so that the zebra pattern appears over the subject being shot (for example, the face of a backlit person).

If it is not necessary to use the zebra pattern to adjust the iris, set the ZEBRA switch to OFF.

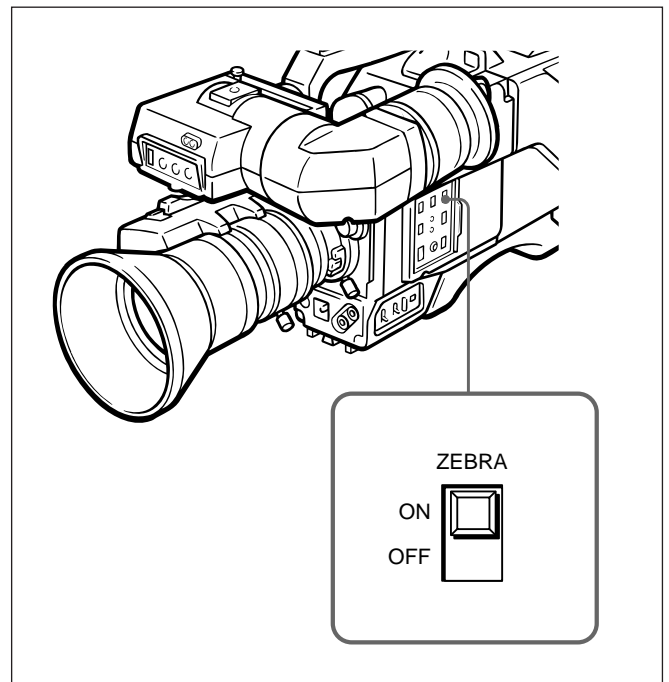

## Synchronizing Two or More Cameras (Without Using a Camera Control Unit)

When a BS or VBS signal is connected to the GEN LOCK IN connector on the camera adaptor, the camera synchronizes with the connected signal. Use the GEN LOCK IN connector when you are using two or more cameras without a camera control unit. (See the illustrations below for sample connections.)

### Connecting two or more cameras to a VTR

Camera 2 synchronizes with Camera 1.

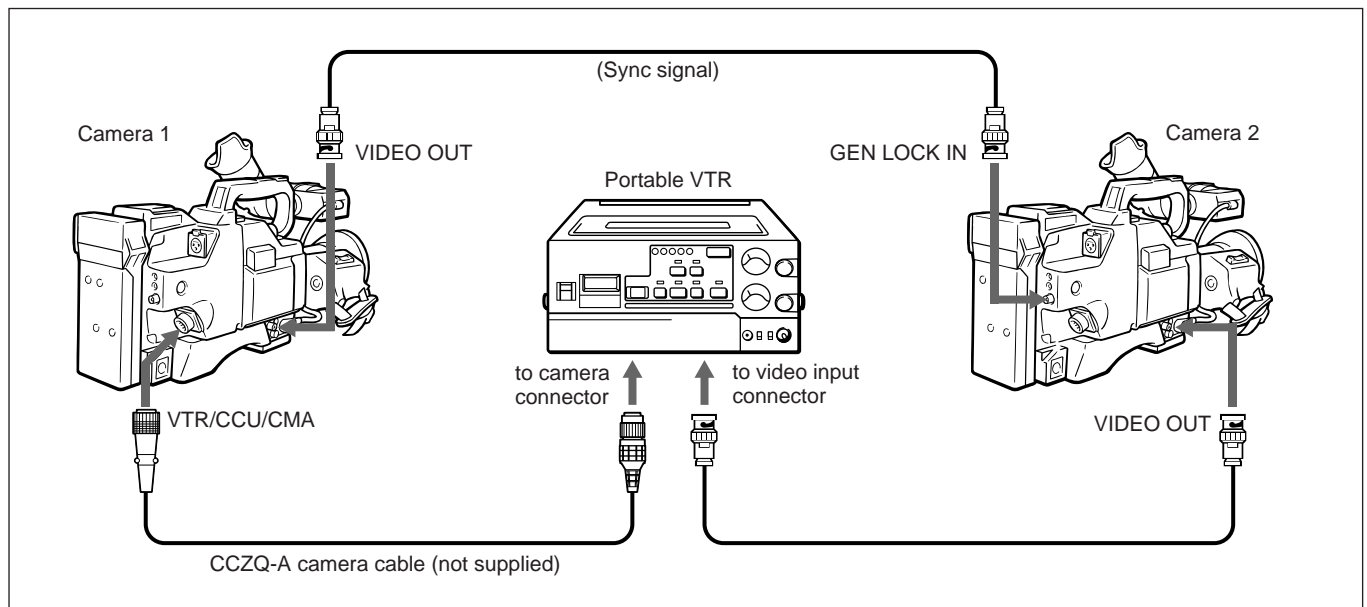

### Connecting two or more cameras and a special-effects generator

Camera 1 and Camera 2 synchronize with a special-effects generator.

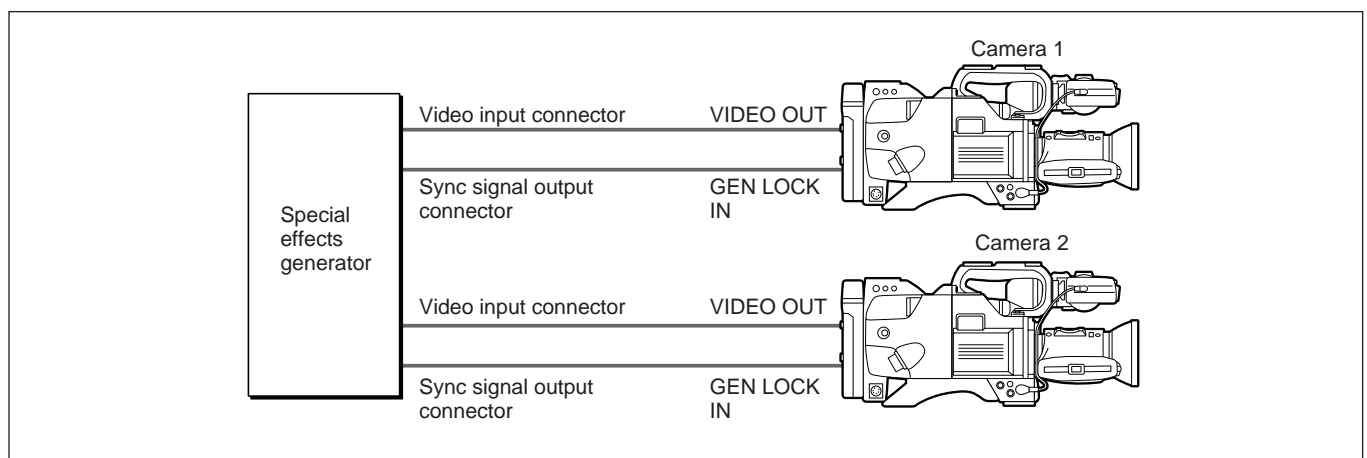

---

### **Adjustment of the picture tone for two or more cameras**

When two or more cameras are used simultaneously in connection with a special-effects generator, supply each camera with the same reference signal and adjust each camera to get the same picture tone. Adjust the SC (subcarrier) phase and the H (horizontal) phase following the procedures described below.

#### **Subcarrier phase adjustment**

Adjust the subcarrier phase roughly with the SC PHASE selector, and make fine adjustment using the SC PHASE control. Use a vectorscope to make the adjustment easily.

#### **Horizontal phase adjustment**

Adjust the horizontal phase with the H PHASE control. Use a waveform monitor or an oscilloscope to make the adjustment easily.

## Title Characters Setting

This camera contains a built-in character generator that allows you to superimpose characters over the picture being shot. Both the picture and the superimposed characters appear on the monitor screen. If a recording VTR is connected to the camera, the superimposed characters can be recorded on the VTR.

### Preparation

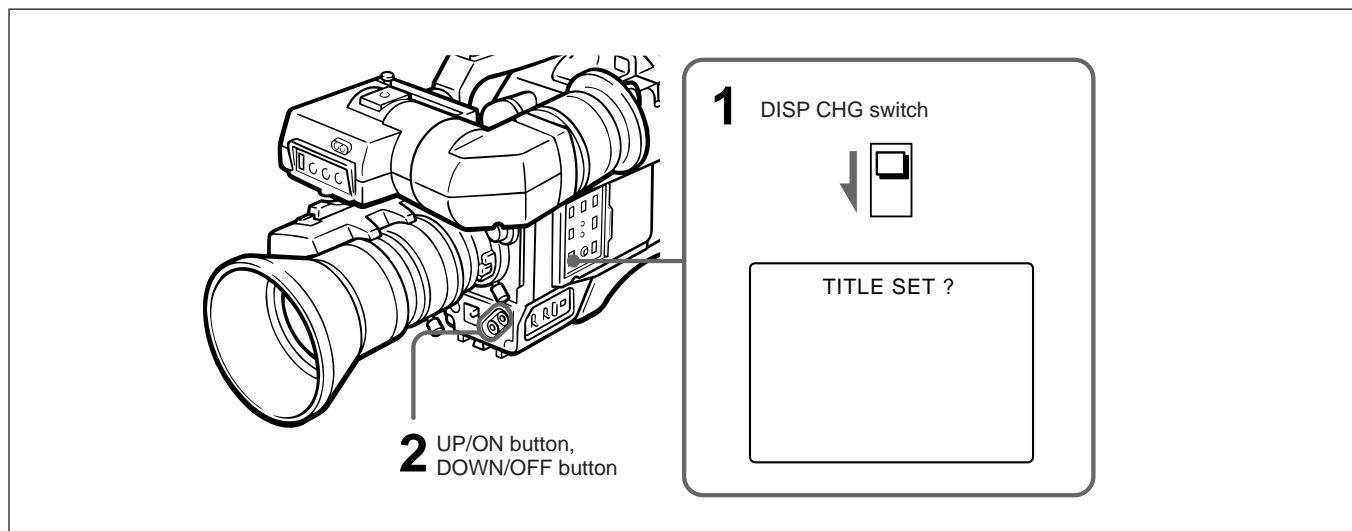

- 1** Press the DISP CHG switch several times until the above indication appears on the viewfinder display screen.
- 2** To put the camera into the title setting mode, press the UP/ON button.

#### To clear all the memorized characters

Press the UP/ON and DOWN/OFF buttons at the same time.

# Advanced Operations

## Setting procedure

Set title characters one by one choosing them from the display using the UP/ON and DOWN/OFF buttons. Up to 12 characters can display on one line. Up to 4 lines can be displayed. Title characters, once set, remain in the memory of the camera, and are not erased when the power is turned off.

## Moving the cursor

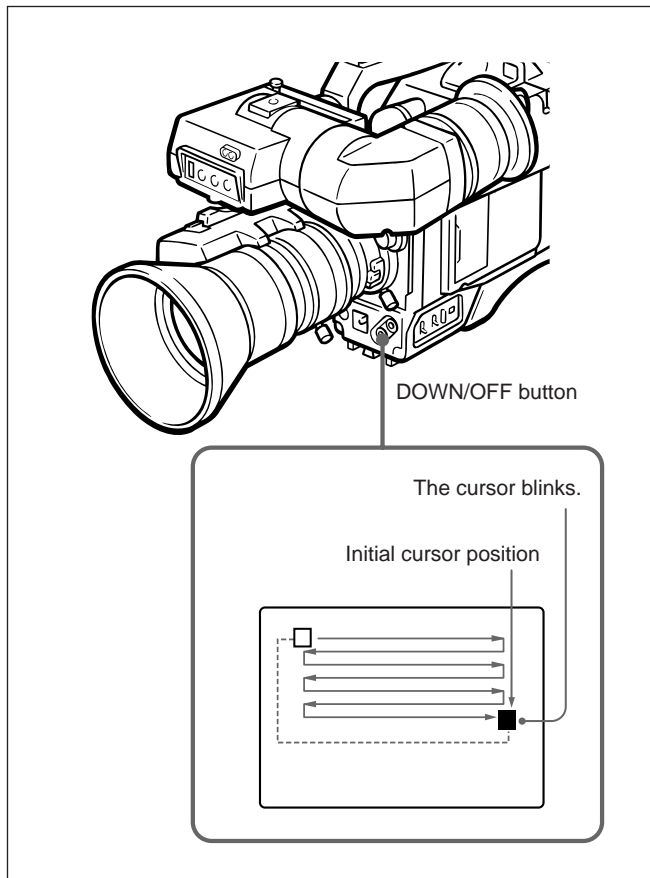

## Setting title characters

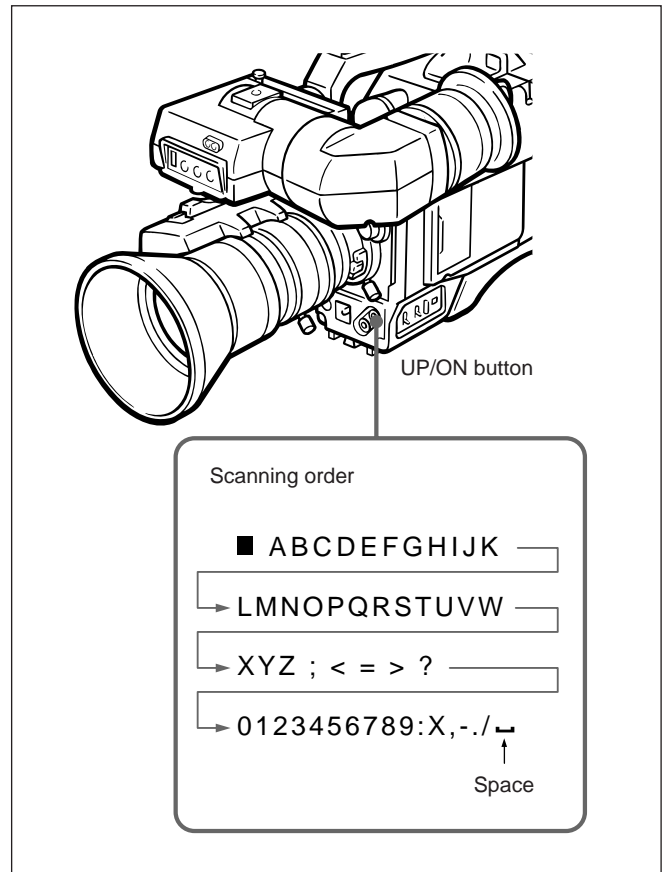

- 1** To set characters and letters from the display, press the UP/ON button repeatedly until the cursor flashes on the character you want to set.  
**To change the characters in reverse alphabetical order**  
While pressing the UP/ON button, press the DOWN/OFF button.
- 2** Press the DOWN/OFF button to set the selected character.  
The cursor moves one space to the right.
- 3** Repeat the above steps 1 to 2 to set all the characters.

### To replace a character

Return the cursor to the position of the character you want to replace, select the desired character with the UP/ON button, and press the DOWN/OFF button. The characters must be changed one by one as described in the above procedure.

### To move the cursor to the right

Press the DOWN/OFF button repeatedly.

### To move the cursor to the left

While pressing the UP/ON button, press the DOWN/OFF button repeatedly.

### To change the position of the title characters

Press the DOWN/OFF button

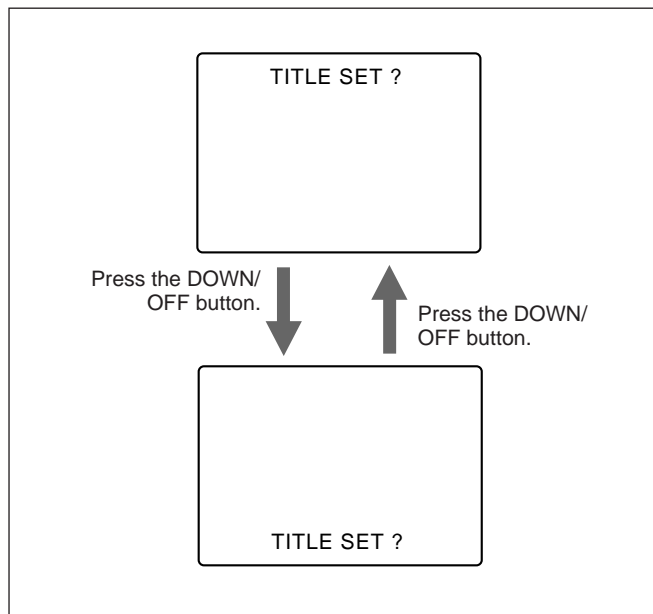

If you are using a VO-8800/8800P portable VTR, do not use the upper character display area because the VTR tape remaining time shows here. Use only the lower character display area.

### To exit character setting mode

Press the DISP CHG switch.

## The next time you use the camera

When you turn on the camera, the memorized characters are displayed on the viewfinder screen at step 1 of "Preparation" (see page 67). To display the characters on the monitor screen and output them to the VTR, press the UP/ON button.

# Advanced Operations

## Connecting a Number of Cameras (Using a Camera Control Unit)

When using a number of cameras in the studio, it may be necessary to use a CCU-M5/M5P/M7/M7P Camera Control Unit to provide video and color sync between cameras, and special effects and other devices to allow switching, wipes and so forth.

In the studio it may also be convenient to use a DXF-40B/40BCE/50B/B0BCE Viewfinder.

The figure below shows an example studio configuration.

*For details, consult your sales representative or supplier.*

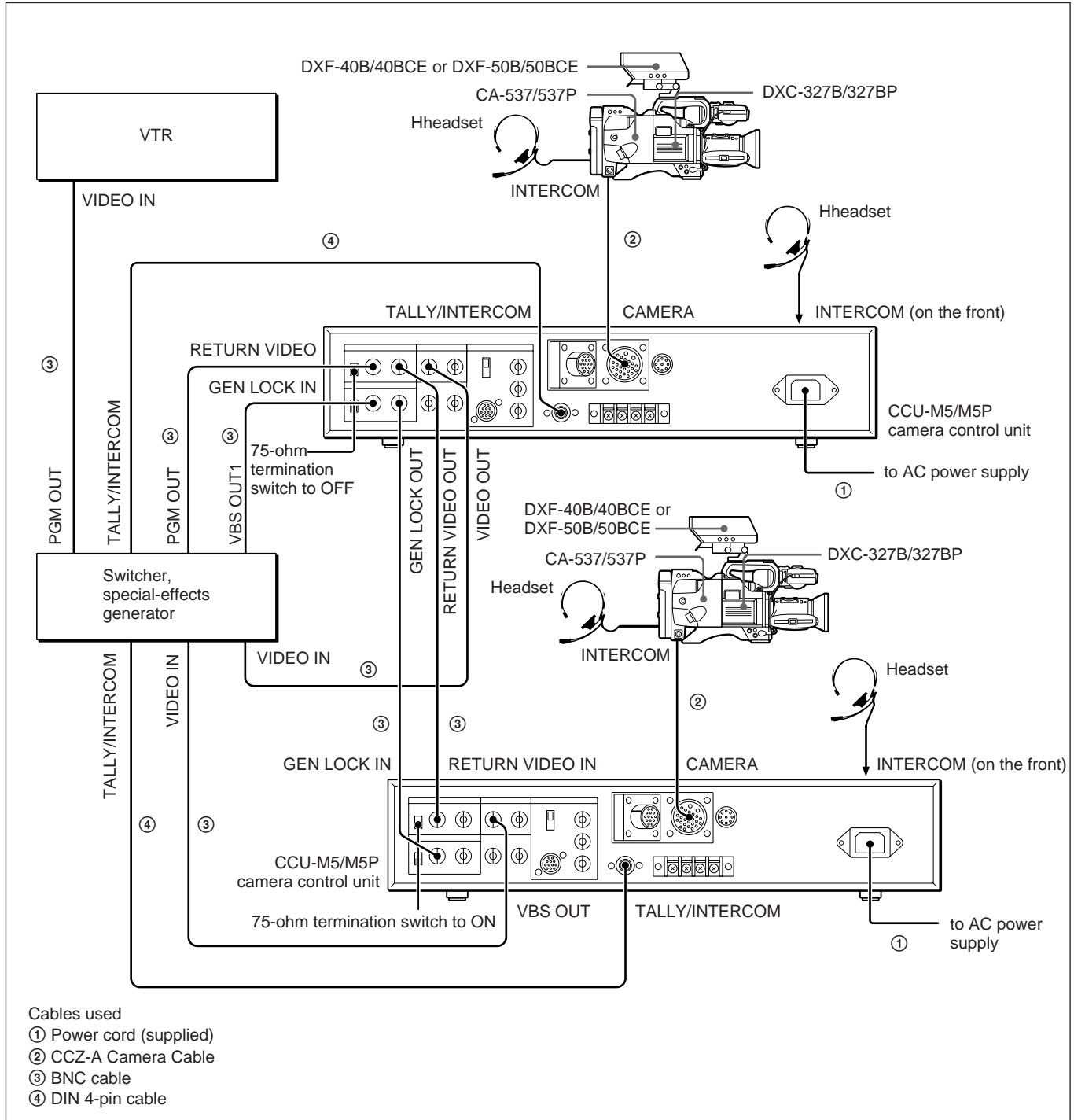

# Using the Optional Carrying Case

## Storing the Camera

Align the camera with the base of the case, and slide the camera in forward.

Checking that the pin at the rear engages correctly, push forward until it locks into place.

### Notes

- Position the eyecup of the viewfinder downward, slide the viewfinder fully rearward and to the left, then fix before storing.
- When an optional microphone (ECM-670/672, etc.) is attached, loosen the microphone fixing screws, move the microphone to the lowest position, and fix before storing.

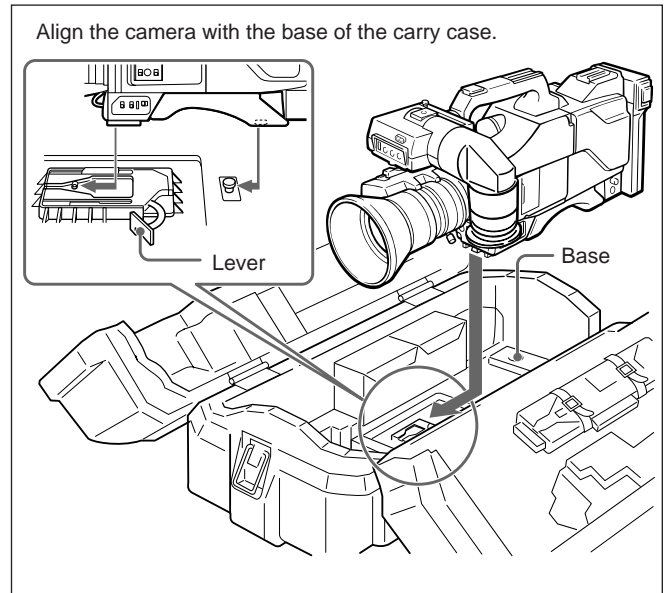

## Example of fully-stored carrying case

### Note

The camera cannot be stored in the LC-421 carrying case with the CAC-4 when the PVV-1/1P/1A/1AP/3/3P is attached.

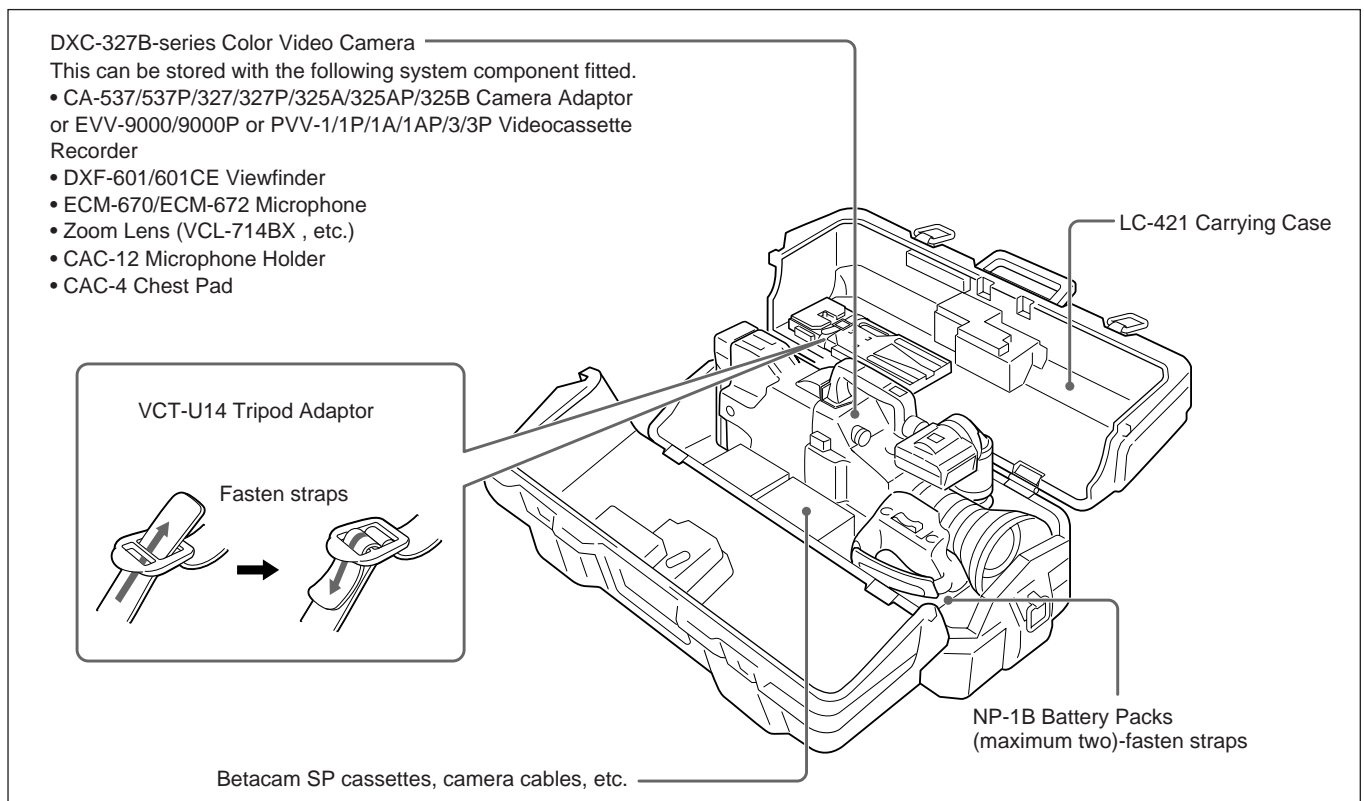

# Specifications

## Camera Head DXC-327B/327BP

Image device	Interline-transfer CCD, 3-chip
Effective picture elements	768 × 494 (h/v) (NTSC) 752 × 582 (h/v) (PAL)
Sensing area	6.4 mm × 4.8 mm (equivalent to a 1/2-inch pickup tube)
Built-in filters	1: 3200K 2: 5600K + 1/16 ND 3: 5600K
Lens mount	Bayonet mount
Signal system	EIA standards, NTSC color system (for DXC-327B) CCIR standards, PAL color system (for DXC-327BP)
Scanning system	525 lines, 2:1 interlace, 30 frames/sec. (NTSC) 625 lines, 2:1 interlace, 25 frames/sec. (PAL)
Scanning frequency	
Horizontal	15.734 kHz (NTSC) 15.625 kHz (PAL)
Vertical	59.94 Hz (NTSC) 50.00 Hz (PAL)
Sync system	Internal External with the BS or VBS signal supplied to the GEN LOCK IN connector (when the CA-537/537P, CA-327/327P is used) or the reference signal input to the VTR/CCU/CMA connector from the GEN LOCK connector of the CCU-M5/M5P/M7/M7P (when the CA-537/537P is used)
Horizontal resolution	700 lines (center)
Minimum illumination	6.0 lx with F1.4, +18 dB
Sensitivity	2000 lx with F9.0 (Typical) at 3200K
Gain selection	0 dB, 9 dB or 18 dB, selectable
Video output	
Composite signal	1.0 Vp-p, sync negative, 75 ohms, unbalanced
Y/C separate signal	
Y:	1.0 Vp-p, sync negative, unbalanced
C:	burst level 0.286 Vp-p (NTSC) 0.3 Vp-p (PAL) without sync

Signal to noise ratio	63 dB (NTSC, Typical) 61 dB (PAL, Typical)
Registration	0.05% for all zone (without lens)
Inputs/Outputs	VIDEO OUT: BNC-type, 75 ohms, unbalanced LENS: 2/3-inch lens connector (6-pin) VF: 8-pin REMOTE: 10-pin
Power requirements	12 V DC
Power consumption	8 W
Operating temperature	-5°C to +45°C (23°F to 113°F)
Storage temperature	-20°C to +60°C (-4°F to 140°F)
Weight	about 2 kg (4 lb 6 oz)
Dimensions	See the illustrations below.

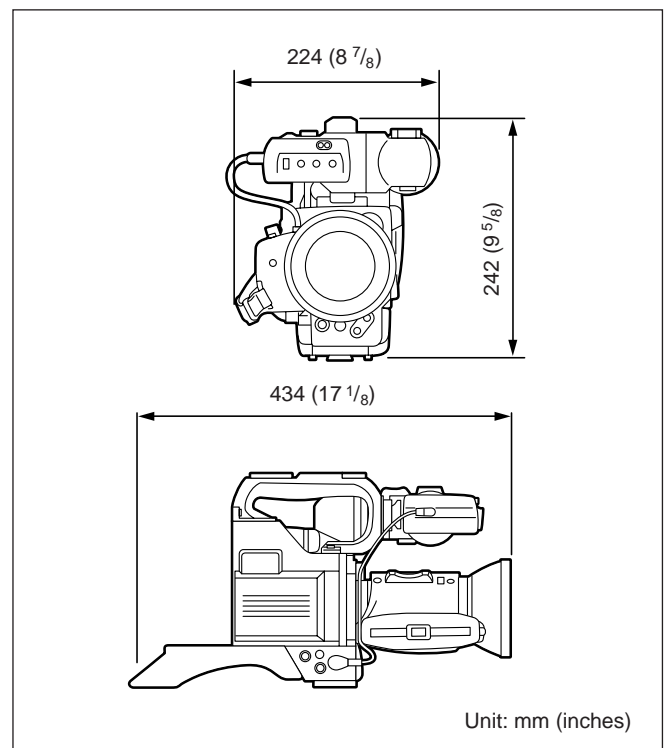

## Camera Adaptor CA-537/537P (Optional)

For details, refer to the CA-537/537P operating instructions.

Inputs/Outputs VTR/CCU/CMA connector:  
Sony Z-type, 26-pin  
DC IN: XLR-type, 4-pin, male  
MIC IN: XLR-type, 3-pin, female  
GEN LOCK IN: BNC-type,  
75-ohms, unbalanced  
EARPHONE: mini jack  
INTERCOM: mini intercom

Power requirements 12 V DC

Power consumption 1.7 W

Operating temperature

-10°C to +45°C (14°F to 113°F)

Storage temperature

-20°C to +60°C (-4°F to +140°F)

Weight About 1.3 kg (2 lb 14 oz)

Dimensions 118 × 205 × 118 mm (w/h/d)  
(4<sup>3</sup>/<sub>4</sub> × 8<sup>1</sup>/<sub>8</sub> × 4<sup>3</sup>/<sub>4</sub> inches)

## Zoom Lens VCL-714BX

Focal length 7.5 mm to 105 mm

Zoom Manual and motorized, selectable  
Zooming ratio: 14×

Maximum aperture ratio

1:1.4 (7.5 to 75 mm) to 1:1.8 (105 mm)

Iris control Manual and auto, selectable  
1.4 to 16 and C (closed)

Range of object field (at the distance of 1.1 meter)

W (wide angle) 660 × 880 mm  
(26 × 34<sup>3</sup>/<sub>4</sub> inches)

T (telephoto) 47 × 63 mm (2<sup>1</sup>/<sub>4</sub> × 3 inches)

Minimum object distance

1.1 m (3<sup>3</sup>/<sub>4</sub> inches)

Filter thread 72 mm dia., 0.75 mm-pitch

Mount Bayonet mount, 1/2 inch

Weight About 1.1 kg (2 lb 10 oz)  
with hood

Dimensions About 110 mm dia. × 186 mm  
(Focus: ∞)  
(4<sup>3</sup>/<sub>8</sub> × 7<sup>1</sup>/<sub>2</sub> inches)

## Viewfinder DXF-601/601CE

Picture tube 1.5-inch monochrome  
Indicators REC/TALLY indicator  
BATT indicator  
SHUTTER indicator  
GAIN UP indicator

Resolution 600 lines

Power requirements 12 V DC

Power consumption 2.1 W

Weight About 640 g (1 lb 2 oz)  
not including a microphone holder

Dimensions About 206 × 79 × 219 mm (w/h/d)  
(7<sup>1</sup>/<sub>4</sub> × 2<sup>3</sup>/<sub>4</sub> × 8<sup>1</sup>/<sub>8</sub> inches)

## Carrying Case LC-421

Weight About 7.7 kg (17 lb)

Dimensions About 790 × 440 × 340 mm  
(w/h/d)  
(31<sup>1</sup>/<sub>8</sub> × 17<sup>3</sup>/<sub>8</sub> × 13<sup>1</sup>/<sub>2</sub> inches)

## Accessories Supplied

VCL-714BX zoom lens (supplied with  
the DXC-327BK/327BPK/327BF/327BPF only) (1)  
DXF-601/601CE electronic viewfinder (supplied with  
the DXC-327BK/327BPK/327BL/327BPL/327BF/  
327BPF only) (1)

LC-421 carrying case (supplied with the DXC-327BF/  
327BPF only) (1)

VCT-U14 tripod attachment (supplied with the  
DXC-327BK/327BPK/327BL/327BPL/327BF/  
327BPF only) (1)

Lens cap (1)

Chart for flange focal length adjustment (1)

Design and specifications are subject to change  
without notice.

# Optional Accessories and Recommended Equipment

## Lens and Accessories

Zoom lens: VCL-714BX

Lens remote control unit: LO-23

Tripod attachment: VCT-U14

## Camera Adaptor

Camera adaptor: CA-537/537P, CA-327/327P,  
CA-325A/325AP/325B,  
CA-511/512/513

Camera adaptor: CMA-8A/8ACE

Camera remote control unit: RM-M7G

## VTR

Betacam format video cassette recorder:

PVV-1/1P/1A/1AP/3/3P

Hi8 format video cassette recorder:

EVV-9000/9000P

Betacam SP portable recorder: BVW-35/35P/50/50P

## Battery Pack and Charger

Battery pack: NP-1B

Battery charger: BC-1WD, BC-410

## Microphone and Accessories

Condenser microphone: ECM-672, ECM-670, C-74

Microphone holder: CAC-12

Microphone cable: EC-0.5C2

## Equipment for Studio Use

Camera control unit CCU-M7/M7P

Camera control unit: CCU-M5/M5P

Special-effects generator: SEG-2550/2550P

Universal chroma keyer: CRK-2000

Wipe pattern extender: WEX-2000/2000P

Electronic viewfinder: DXF-50B/50BCE

Electronic viewfinder: DXF-40B/40BCE

Electronic viewfinder: DXF-601/601CE

Intercom headset: DR-100A

Rack mounting metal: RMM-1800

## Camera Cable and Others

Camera cable with Z-type 26 pin connectors:

CCZ-A2, CCZ-A5, CCZ-A10

CCZ-A25, CCZ-A50, CCZ-A100

Camera cable with Z-type 26 pin and Q-type

14 pin connectors: CCZQ-A2, CCZQ-A5,  
CCZQ-A10, CCZQ-A2AM

Camera cable with Q-type 14-pin connectors:

CCQ-2BRS, CCQ-5BRS, CCQ-10BRS

Camera cable with Q-type 14-pin connectors:

CCQ-10AM, CCQ-25AM, CCQ-50AM,  
CCQ-100AM

Camera cable with Z-type 26-pin and J-type

10-pin connectors: CCZJ-2

Cable extension adaptor: CCZZ-1B, CCZZ-1E

Carrying case: LC-421

Camera rain cover: LCR-1

# Sample Video System Configuration

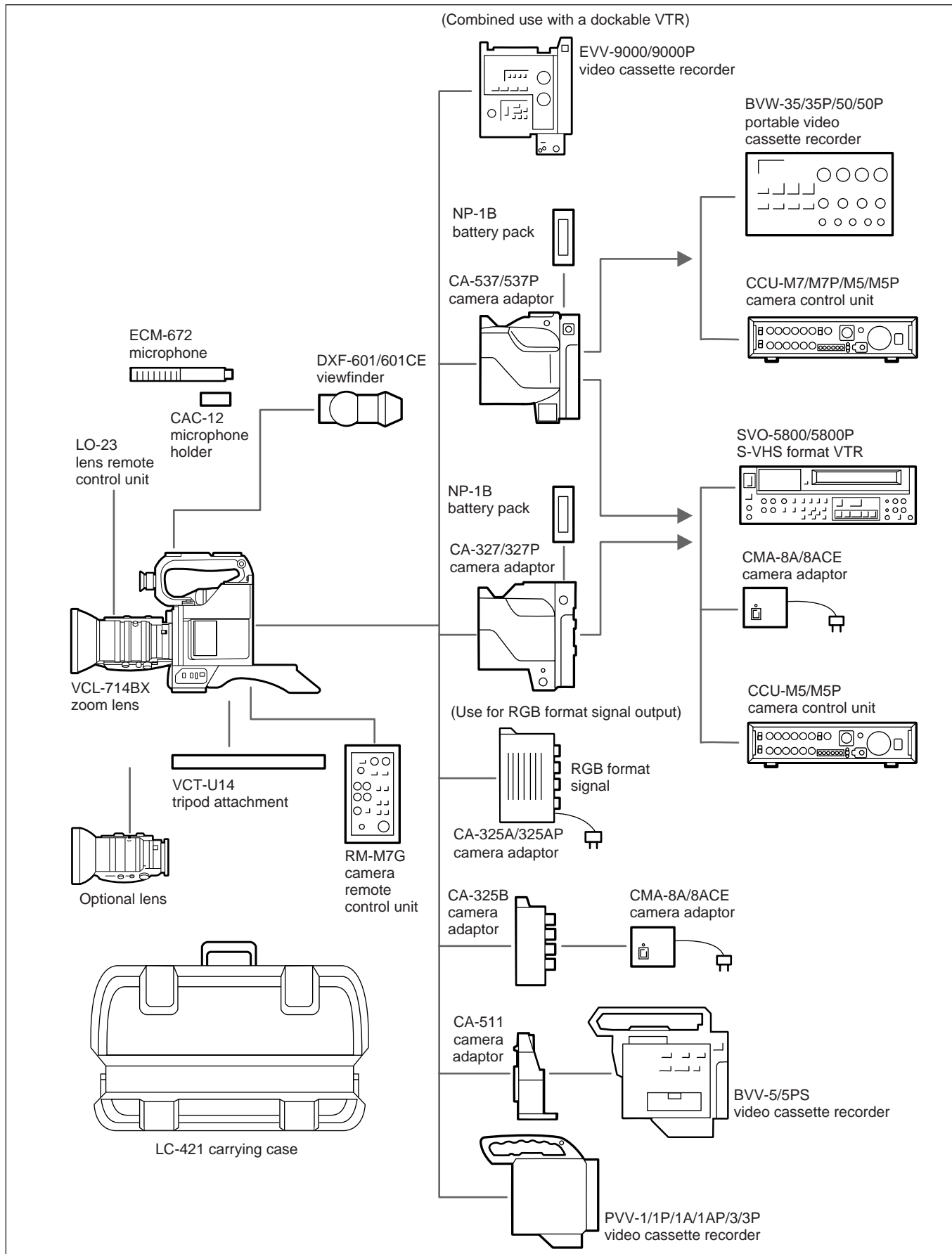

**Black set**

Black set means that the R, G and B signals of a video signal are set to the memorized level to obtain the definite black level for each R, G and B signals. When the black set is adjusted, the black picture can be avoided from being colored by raising the signal level.

**Black balance**

Black balance means to set the black level of a video signal to that of no color when the iris is closed. Adjust the pedestal level of each R, G or B signal so that the signal level of each signal becomes equal.

**Color temperature conversion filter**

All color cameras are designed to operate on a certain color temperature (3200K for the DXC-327B/327BP.) However, the camera must also have the capability of shooting under color temperatures other than 3200K. To obtain the same color as at 3200K, a number of selectable filters which convert color temperature are provided on the camera.

**Color temperature**

The temperature to which a perfectly black body must be heated to match the color of the source being measured. Color temperature measurements are expressed in kelvins (K). For example, color temperature of 6500K means the color which is obtained by heating a perfectly black body at 6500K.

**E-E picture**

The video signal input to the VTR passes through the VTR amplifier and outputs through the video output connector without being recorded onto the tape.

**Phantom powering system**

The power is supplied to a microphone overlaid on an audio signal. This system does not require an optional cable for supplying power.

**Return video**

The “return video” is the picture from a VTR during recording, the playback picture during playback, or the signal from a control console such as a video switcher. Using this picture, the camera operator can check the recording conditions.

**Subcarrier**

Color information that is contained within a composite video signal. The signal amplitude is for color saturation (chromaticity) and its phase to color burst is for hue (color).

**S-video input connector**

This connector accepts and supplies the luminance and chrominance signals separately. So no interference occurs between the luminance and chrominance signals which allows high resolution pictures.

**White balance**

The variation of color temperature due to the type of illuminant must be compensated electrically so that a white object picked up by a camera can be seen as clear white. This is white balance adjustment.

- 
- A**  
Accessories 4  
    usable with DXC-327B/327BP-series 5  
Aliasing 6
- 
- B**  
BATT indicator 21, 46  
BATT XX.XV indication 47  
Battery, charging 44  
    life 44  
    pack 40  
Black balance 54, 76  
    adjusting 55  
Black set 54, 76  
Brightness (BRIGHT) control 21, 50
- 
- C**  
Camera adaptor 16  
    attaching 22  
    connections 22  
Camera cable 32 to 34  
Camera control unit 34, 64, 70  
    connecting 34  
    in studio 70  
    inoperable functions 35  
Camera head 8  
Carrying case 71  
CCD image sensor 6  
Center marker 7, 9  
Close ups 62  
Color bars 50, 51  
Color temperature 13, 76  
    table 54  
Contrast (CONTRAST) control 21, 50
- 
- D**  
Detail level 63  
Diopter 21, 50  
DISP CHG switch 9, 49
- 
- E**  
E-E 45, 76  
Electric shutter 15, 59
- 
- F**  
Ff adjustment ring 19, 61  
Filter 13, 54  
    Color temperature conversion 76  
    ND 54  
Flange focal length, adjusting 61  
Focus 19, 43
- 
- G**  
GAIN UP indicator 21, 46  
Gain 15, 63
- 
- H**  
HAD sensor 7  
Horizontal phase (H PHASE) adjustment 13, 66
- 
- I**  
Indicators 21, 46  
Instant automatic iris adjustment 19, 52  
Iris reference level 53  
Iris 19, 52
- 
- L**  
LOW LIGHT indication 47
- 
- M**  
Macro 19, 62  
Master pedestal level 58  
Microphone, attaching 29  
    built-in 11  
    connecting 33
- 
- N**  
NTSC system 5  
ND filter 54
- 
- P**  
PAL system 5  
Peaking 21, 50, 63  
Phantom power supply system 17, 76
- 
- R**  
REC/TALLY indicator 21, 46  
Reducing, screen objects 62  
Remote control unit 36  
Return video 76
- 
- S**  
Safety zone marker 7, 9  
Sharpness 21, 50, 63  
SHUTTER indicator 21, 46  
Shutter speed 59  
    switch 15, 59  
Smear phenomena 6  
Special-effects generator 70
- 
- Standby 9  
Sub-carrier phase (SC PHASE)  
    adjustment 13, 66  
Synchronizing, without camera control  
    unit 65  
    with special-effects generator 70
- 
- T**  
Tally (lamp, switch) 21  
Telephoto shots 60  
Title characters 7, 67  
Tripod attachment 31
- 
- V**  
Vertical smear 6  
Video level 63  
Viewfinder 20  
    attaching 27  
    indicator 46  
    setting indications 48  
    warning indications 47
- 
- W**  
Warning indications 47  
White balance 56, 76  
    adjusting 56  
Wide angle shots 60
- 
- Z**  
Zebra pattern 7, 9, 52, 63  
Zoom lens 18  
    attaching 25  
Zooming, (manual, motorized) 60





